

Behavior of Cells in a Bioreactor

A. Models to describe cell growth

1. Introduction

The growth rate of a population is proportional to the number of organisms present in that population. If each member of that population has the same mass, then the growth rate is proportional to the mass concentration of members (X = cell mass concentration):

$$\frac{dX}{dt} \propto X$$

The proportionality constant μ is called the specific growth rate. (units are time^{-1})

Notes:

- μ can be positive (growth) or negative (death). Usually μ is used in the context of cell growth.
- μ is a function of nutrient supply and therefore can be a function of time (i.e., if nutrient supply is changing with time).

2. Empirical models to describe cell growth rate

In general, $\mu = f(S, P, I, X, \text{pH}, T, \text{osmotic pressure})$

S = substrate concentration

P = product concentration

I = inhibitor concentration

Generally, non-segregated, unstructured, deterministic and empirical models are used to describe cell growth rate.

a) Monod

$$\mu = \frac{\mu_{\text{MAX}} S}{K_S + S}$$

K_S = "Monod Constant"
(typically very small)

So, $\mu \approx \mu_{\text{MAX}}$

For multiple substrates
(such as nitrogen)...

$$\mu = \frac{\mu_{\text{MAX}} S}{K_S + S} \frac{N}{K_N + N}$$

b) Modified Monod

$$\mu = \frac{\mu_{\text{MAX}} S}{K_S + K_{S_0} S_0 + S}$$

S_0 = Initial Substrate
Concentration

c) Contois

$$\mu = \frac{\mu_{\text{MAX}} S}{K_{SX} X + S}$$

Predicts $\mu \propto \frac{1}{X}$ at low S

Predicts $\mu \rightarrow 0$ at high X

d) Monod-like "Noncompetitive
Inhibition"

$$\mu = \frac{\mu_{\text{MAX}} S}{K_S + S} \frac{K_I}{K_I + I}$$

e) Monod-like "Noncompetitive
Product Inhibition"

$$\mu = \frac{\mu_{\text{MAX}} S}{K_S + S} \frac{K_P}{K_P + P}$$

Monod model is most widely used.

B. Model to describe substrate utilization

A substrate is consumed by an organism. The mass/energy of the substrate goes towards three uses:

1. Maintenance

The substrate may be converted by the organism into energy for it to maintain its standard of living. This concept is called maintenance requirement. The majority of a cell's maintenance energy goes towards maintaining osmotic and ionic gradients across the cell membrane.

The rate of substrate consumed in order to maintain the cells is proportional to the number of cells or the mass density:

$$-\left. \frac{dS}{dt} \right|_{\text{Maintenance}} \propto X$$

or

$$-\left. \frac{dS}{dt} \right|_{\text{Maintenance}} = m_S X$$

Where m_S is the **maintenance coefficient**. The units of m are (for example) g substrate/g cell·h.

The higher the value of the maintenance coefficient, the more substrate goes towards maintaining the culture without contributing to cell mass or product formation. Maintenance is the “overhead” costs of the organism for doing business.

Maintenance is defined in terms of any single substrate needed for cells under non-growth conditions. Usually maintenance coefficients are considered for two substrates – carbon (m_s) and oxygen (m_o).

Organism	substrate	m_s	m_o
<i>Aerobacter aerogenes</i>	glucose	0.054 g/gh	0.054 g/gh
<i>A. aerogenes</i>	glycerol	0.096	0.109
<i>A. aerogenes</i>	citrate	0.058	0.048
<i>Penicillium chrysogenum</i>	glucose	0.022	0.024

2. Cell mass

The substrate may be used for the production of new cellular components which ultimately become new cells. The rate of substrate consumed to produce more cells is proportional to the rate of new cells produced:

$$- \frac{dS}{dt} \Big|_{\text{Cells}} \propto \frac{dX}{dt}$$

By convention, the proportionality is written in front of the substrate consumption rate term:

$$- Y_{X/S} \frac{dS}{dt} \Big|_{\text{Cells}} = \frac{dX}{dt}$$

or

$$-\frac{dS}{dt} \Big|_{\text{Cells}} = \frac{1}{Y_{X/S}} \frac{dX}{dt}$$

where $Y_{X/S}$ is the **cell yield coefficient**. Cell yield coefficients may be written for any substrate:

$$Y_{X/S} = \frac{\text{g cell formed}}{\text{g substrate consumed}}$$

$$Y_{X/O} = \frac{\text{g cell formed}}{\text{g oxygen consumed}}$$

Organism	substrate	$Y_{X/S}$	$Y_{X/O}$
<i>Candida utilis</i>	glucose	0.51 g/g	1.30 g/g
<i>Candida utilis</i>	acetic acid	0.36	0.62
<i>Candida utilis</i>	ethanol	0.68	0.58

3. Products

The substrate may be used for the synthesis of chemical products. These are usually at the termination of biochemical pathways.

Some useful terms:

$$\text{Volumetric rate of product formation} = Q_P = \frac{dP}{dt}$$

$$\text{Specific rate of product formation} = q_P = \frac{1}{X} \frac{dP}{dt}$$

There are several relationships which can exist between the rate of product formation (q_P) and the specific rate of substrate consumption (q_S) or specific growth rate (μ).

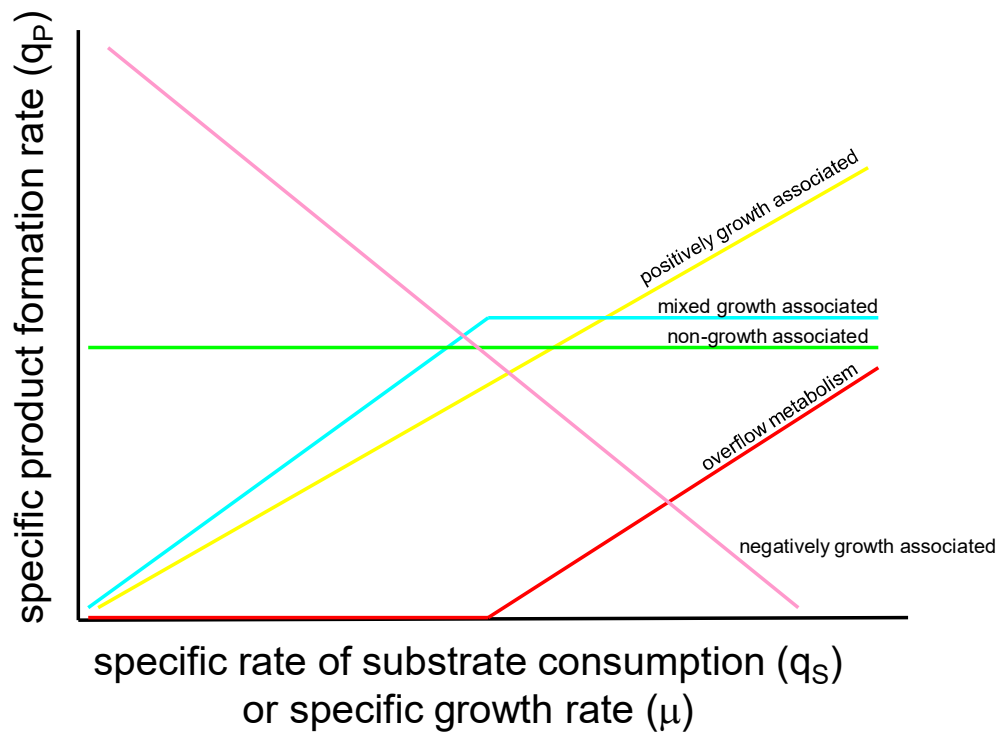

a. Growth associated

In this case a simple stoichiometric relationship exists between the product formation rate and substrate utilization rates.

$$\begin{aligned} - \frac{dS}{dt} \Big|_{\text{Products}} &\propto \frac{dP}{dt} \\ - Y_{P/S} \frac{dS}{dt} \Big|_{\text{Products}} &= \frac{dP}{dt} \\ - \frac{dS}{dt} \Big|_{\text{Products}} &= \frac{1}{Y_{P/S}} \frac{dP}{dt} \end{aligned}$$

where $Y_{P/S}$ is a **product yield coefficient** based on substrate. Such a yield coefficient can be written for each substrate (and for each product):

$$Y_{P/S} = \frac{\text{g product formed}}{\text{g substrate consumed}}$$

$$Y_{P/O} = \frac{\text{g product formed}}{\text{g oxygen consumed}}$$

Growth associated products form simultaneously with and as a natural consequence of cell growth. Thus, the rate of product formation is also proportional to growth rate:

$$\frac{dP}{dt} \propto \frac{dX}{dt}$$

$$\frac{dP}{dt} = Y_{P/X} \frac{dX}{dt}$$

where $Y_{P/X}$ is the specific product yield coefficient.

Note:

$$\frac{dP}{dt} = Y_{P/X} X \frac{1}{X} \frac{dX}{dt}$$

$$Q_P = Y_{P/X} \mu X$$

$$q_P = Y_{P/X} \mu$$

growth
associated
products

b. Non-growth associated

The specific rate of product formation is a constant.

$$q_P = \beta$$

$$Q_P = \beta X$$

c. Mixed-growth associated

$$q_P = \alpha\mu + \beta \quad \text{Luedeking-Piret Equation}$$

$$Q_P = \alpha\mu X + \beta X$$

d. My personal preference, but a lot of work

When you have engineered an organism to accumulate a new product, you often do not really know what q_P depends on.

Conduct (chemostat) experiment (using different nutrient limitations) at various dilution rates, measure q_S and q_P , and then come up with an empirical relationship between the specific rate of product formation is a constant.

$$q_P = f(\mu)$$

$$q_P = f(q_S)$$

4. Summary

Thus, the total substrate utilization may be written:

$$-\left. \frac{dS}{dt} \right|_{\text{Total}} = -\left. \frac{dS}{dt} \right|_{\text{Maint}} - \left. \frac{dS}{dt} \right|_{\text{Cells}} - \left. \frac{dS}{dt} \right|_{\text{Products}}$$

$$-r_S = -\left. \frac{dS}{dt} \right|_{\text{Total}} = m_S X + \frac{\mu X}{Y_{X/S}} + \frac{Q_P}{Y_{P/S}} = Q_S$$

$$q_S = \frac{Q_S}{X}$$

C. General material balances

1. Derivation

Consider the following well-mixed system:

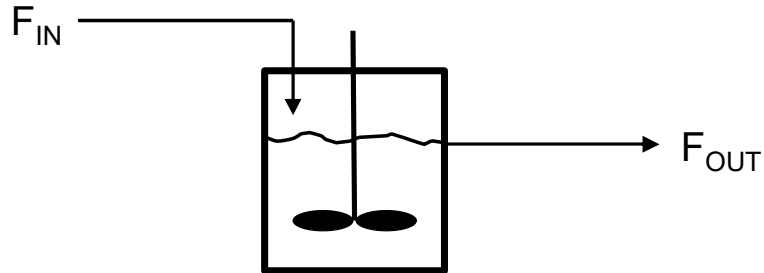

F_{IN} = flowrate of fluid into system (vol/time)

F_{OUT} = flowrate of fluid out of system (vol/time)

V = volume of fluid in system

Other key variables (a reminder):

X = concentration of cells (mass/vol)

S = concentration of substrate (mass/vol)

P = concentration of product (mass/vol)

W = concentration of water (mass/vol)

r_i = mass rate of i generation (mass/vol·time)

Four (or more) material balances can be written:

$$\text{Accumulation} = \text{In} - \text{Out} + \text{Gen}$$

a) Cells:

$$\frac{d(VX)}{dt} = F_{\text{IN}}X_{\text{IN}} - F_{\text{OUT}}X_{\text{OUT}} + r_XV$$

b) Limiting substrate:

$$\frac{d(VS)}{dt} = F_{\text{IN}}S_{\text{IN}} - F_{\text{OUT}}S_{\text{OUT}} + r_SV$$

Note: we expect r_S to be negative

c) Product:

$$\frac{d(VP)}{dt} = F_{\text{IN}}P_{\text{IN}} - F_{\text{OUT}}P_{\text{OUT}} + r_PV$$

d) Water:

$$\frac{d(VW)}{dt} = F_{\text{IN}}W_{\text{IN}} - F_{\text{OUT}}W_{\text{OUT}} + r_WV$$

2. Common simplifications

a) Concentration of water remains unchanged

$$W_{\text{IN}} = W_{\text{OUT}} = W$$

and insignificant water is generated

$$r_w = 0$$

b) Reactor is well-mixed

$$P_{\text{OUT}} = P$$

$$S_{\text{OUT}} = S$$

$$X_{\text{OUT}} = X$$

c) No product and no cells in feed

$$P_{\text{IN}} = 0; X_{\text{IN}} = 0$$

d) Cell growth rate is greater than cell death rate and can be expressed as:

$$r_x = \mu X$$

Results of these simplifications:

a) Cells:
$$\frac{d(VX)}{dt} = -F_{OUT}X + \mu XV$$

b) Substrate:
$$\frac{d(VS)}{dt} = F_{IN}S_{IN} - F_{OUT}S + r_S V$$

c) Product:
$$\frac{d(VP)}{dt} = -F_{OUT}P + r_P V$$

d) Water:
$$\frac{dV}{dt} = F_{IN} - F_{OUT}$$

D. Batch operation

1. Introduction

A batch process is a closed culture which occurs when $F_{OUT} = 0$ and $F_{IN} = 0$.

The volume is essentially constant (except for pH control, anti-foam addition, etc.).

All nutrients are provided **initially** into the culture. The cells are introduced into that culture, and grow until one or more nutrient(s) is exhausted. This one nutrient is often called the 'limiting nutrient'. However, the cells are essentially never actually limited for their growth during the course of a batch process.

Returning to differential equations to describe batch process ($F_{OUT}, F_{IN} = 0; V = \text{constant}$):

a) Cells:
$$\frac{dX}{dt} = +\mu X$$

b) Substrate:
$$\frac{dS}{dt} = +r_S$$

c) Product:
$$\frac{dP}{dt} = +r_P$$

2. Incorporating growth and substrate utilization models

Cells:
$$\frac{dX}{dt} = \mu X$$

In order to use this equation, we need a relationship between μ and S (and other variables as desired).

For example, Monod model for two substrates (S and N):

$$\mu = \frac{\mu_{MAX} S}{K_S + S} \frac{N}{K_N + N}$$

So,

$$\frac{dX}{dt} = \frac{\mu_{MAX} S X}{K_S + S} \frac{N}{K_N + N}$$

Energy substrate: $\frac{dS}{dt} = + r_S$

In order to use this equation, we need an expression for r_S , which we have derived previously.

$$-r_S = m_S X + \frac{\mu X}{Y_{X/S}} + \frac{Q_P}{Y_{P/S}}$$

We will consider the case where no product is formed ($Q_P = 0$). Incorporating two-substrate Monod model into substrate equation:

$$\frac{dS}{dt} = -m_S X - \frac{\mu_{MAX} S N X}{Y_{X/S} (K_S + S)(K_N + N)}$$

Non-energy substrate: $\frac{dN}{dt} = + r_N$

A “substrate” model may be used for every nutrient. However, typically no other nutrient (like N) is directly incorporated into products ($Q_P = 0$), and no other nutrient except oxygen is used for maintenance ($m_N = 0$). Thus,

$$-r_N = \frac{\mu X}{Y_{X/N}}$$

$$\frac{dN}{dt} = - \frac{\mu_{MAX} S N X}{Y_{X/N} (K_S + S)(K_N + N)}$$

In summary

The three differential equations describing cell growth (X) and substrate utilization (S and N) are:

$$\frac{dX}{dt} = \frac{\mu_{MAX}SNX}{(K_S + S)(K_N + N)}$$

$$\frac{dS}{dt} = -m_S X - \frac{\mu_{MAX}SNX}{Y_{X/S}(K_S + S)(K_N + N)}$$

$$\frac{dN}{dt} = - \frac{\mu_{MAX}SNX}{Y_{X/N}(K_S + S)(K_N + N)}$$

Note

$$\frac{dX}{dt} \propto \frac{dN}{dt}$$

3. Simulation

Parameters:

$$\begin{aligned} m_S &= 0.05 \text{ g/gh}^* \\ K_S &= 10 \text{ mg/L} = 0.01 \text{ g/L}^* \text{ (S = glucose)} \\ K_N &= 0.01 \text{ g/L} \ddagger \\ \mu_{MAX} &= 0.80 \text{ h}^{-1} \\ Y_{X/S} &= 0.44 \text{ g/g}^* \\ Y_{X/N} &= 8.0 \text{ g/g} \ddagger \end{aligned}$$

Simulated Cases:

$$\begin{aligned} \text{Case I: "Carbon-Limited"} \\ X_0 = 0.005 \text{ g/L} \quad S_0 = 30 \text{ g/L} \quad N_0 = 5 \text{ g/L} \end{aligned}$$

$$\begin{aligned} \text{Case II: "Nitrogen-Limited"} \\ X_0 = 0.005 \text{ g/L} \quad S_0 = 30 \text{ g/L} \quad N_0 = 1 \text{ g/L} \end{aligned}$$

† unpublished data
‡ yeast; Cramer et al. 2002
* see subsequent pages

Case I: "Carbon-Limited"

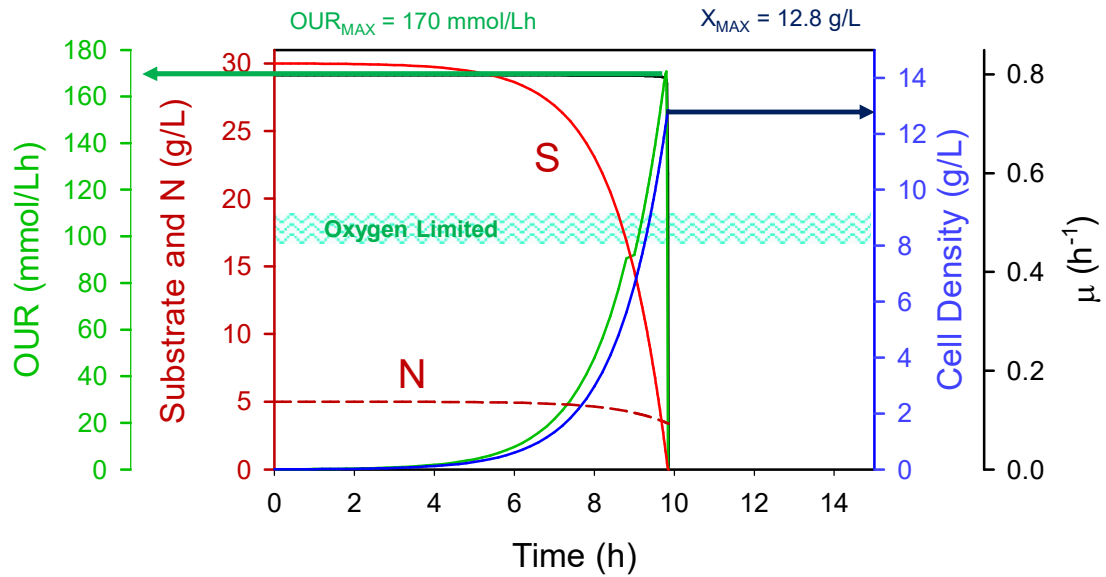

Case II: "Nitrogen-Limited"

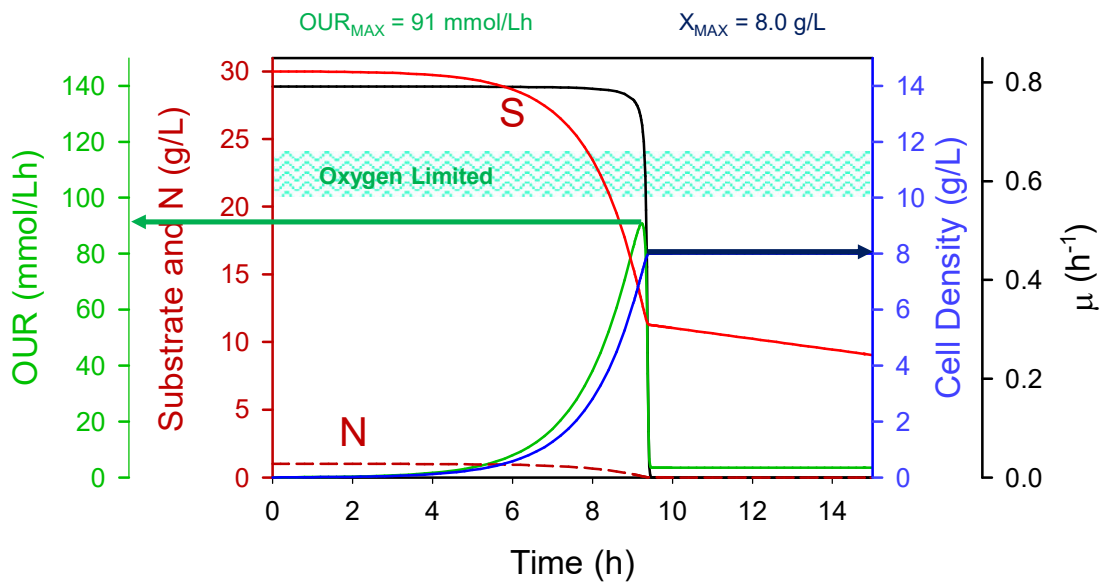

4. Conclusions:

- In a batch culture, the cells grow at their maximum specific growth rate (μ_{MAX}) for essentially the entire process. Changes in the environment and presence of products often slow cell growth due to inhibition.
- If cells exhaust another required nutrient before the carbon/energy source is depleted, the carbon/energy source will continue to be consumed slowly. If NADH or ATP is generated from the conversion of a carbon/energy source to a product, then this product often continues to be formed in the absence of cell growth.
- Batch processes show a very high oxygen uptake rate (OUR) for the amount of biomass generated.
- A “lag” phase is difficult to model.

E. Chemostat operation

A chemostat occurs when $F_{OUT} = F_{IN} = F$

The volume is therefore constant and the concentrations will reach a steady-state.

Define: Dilution rate = $D = \frac{F}{V}$ [time⁻¹]

The material balances become....

a) Cells:
$$\frac{dX}{dt} = -DX + \mu X$$

b) Substrate:
$$\frac{dS}{dt} = D(S_{IN} - S) + r_S$$

c) Product:
$$\frac{dP}{dt} = -DP + r_P$$

But, at steady-state, there will be no change in concentrations...

The material balances become....

a) Cells:
$$DX = \mu X$$

b) Substrate:
$$D(S_{IN} - S) = -r_S$$

c) Product:
$$DP = r_P$$

Let us now look at each one of these results....

1. Cells

$$DX = \mu X$$

or

$$D = \mu$$



This equation states that the cells' specific growth rate is determined by the dilution rate.

We have already defined a *maximum specific growth rate* as μ_{MAX} . If $D > \mu_{MAX}$, then the cells will not be able to grow fast enough for the flowing fluid. This condition is called **wash-out**. Note that:

$$\frac{dX}{dt} = -DX + \mu X$$

2. Substrate

$$D(S_{IN} - S) = -r_S$$

Before this equation is used, we must have a model for the value of r_S . We previously have shown:

$$-r_S = m_S X + \frac{\mu X}{Y_{X/S}} + \frac{q_P X}{Y_{P/S}}$$

Commonly the term $\frac{q_P X}{Y_{P/S}}$ is taken to be small:

$$-r_S = m_S X + \frac{\mu X}{Y_{X/S}}$$

The material balance becomes:

$$D(S_{IN} - S) = m_S X + \frac{DX}{Y_{X/S}}$$

or

$$\frac{D(S_{IN} - S)}{X} = m_S + \frac{D}{Y_{X/S}}$$

We will now rename $Y_{X/S}$ as the true biomass yield or the maximum biomass yield. We do this to distinguish it from the observed biomass yield...

Define: $\frac{X}{(S_{IN} - S)} = Y_{X/S}^{OBS}$

$Y_{X/S}^{OBS}$ = Observed Biomass Yield or Apparent Biomass Yield

So:

$$\frac{D}{Y_{X/S}^{OBS}} = m_S + \frac{D}{Y_{X/S}}$$

3. Biomass yield

$$\frac{D}{Y_{X/S}^{OBS}} = m_s + \frac{D}{Y_{X/S}}$$

This equation really describes $Y_{X/S}^{OBS} = f(D)$. m_s and $Y_{X/S}$ are parameters. Note that the observed biomass yield is a function of dilution rate, but the true biomass yield is not. The equation may be written:

$$Y_{X/S}^{OBS} = \frac{DY_{X/S}}{D + m_s Y_{X/S}}$$

This equation expresses a saturation model (i.e., like Michaelis-Menten kinetics)

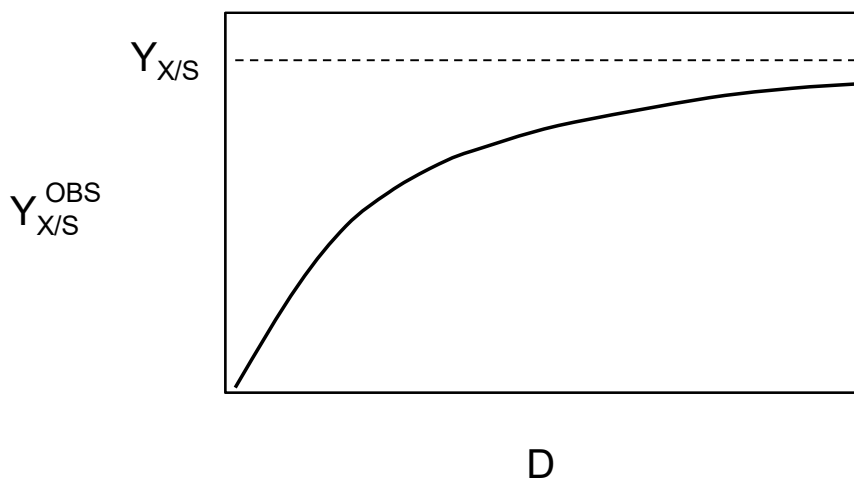

At high dilution rate $Y_{X/S}^{OBS} \rightarrow Y_{X/S}$

4. Calculation of maintenance coefficient and true biomass yield

The easiest way to determine the value of the maintenance coefficient and the true biomass yield is to conduct several chemostats at different dilution rates (D), and calculate the observed biomass yield. Then make one of three possible plots of data.

1) Pirt Plot (Pirt, 1965)

Rewrite equation as

$$\frac{1}{Y_{X/S}^{OBS}} = \frac{m_s}{D} + \frac{1}{Y_{X/S}}$$
$$y = mx + b$$

Plot $\frac{1}{D}$ ("x") versus $\frac{1}{Y_{X/S}^{OBS}}$ ("y")

$$\text{Intercept} = \frac{1}{Y_{X/S}}$$

$$\text{Slope} = m_s$$

2) Hofstee Plot

Rewrite equation as

$$Y_{X/S}^{OBS} = \frac{-m_S Y_{X/S} Y_{X/S}^{OBS}}{D} + Y_{X/S}$$

$$y = mx + b$$

Plot $\frac{Y_{X/S}^{OBS}}{D}$ ("x") versus $Y_{X/S}^{OBS}$ ("y")

$$\text{Intercept} = Y_{X/S}$$

$$\text{Slope} = -m_S Y_{X/S}$$

This plot is almost never used

3) Tempest Plot (Tempest & Neijssel, 1985)

Leave equation as

$$\frac{D}{Y_{X/S}^{OBS}} = \frac{D}{Y_{X/S}} + m_S$$

$$y = mx + b$$

Plot D ("x") versus $\frac{D}{Y_{X/S}^{OBS}}$ ("y")

$$\text{Intercept} = m_S$$

$$\text{Slope} = \frac{1}{Y_{X/S}}$$

Comments:

$Y_{X/S}$ is sometimes referred to as maximum yield coefficient or true yield coefficient.

$Y_{X/S}$ usually refers to carbon/energy source, and is sometimes given a more specific name biomass yield coefficient on glucose or biomass yield from glucose, etc.

Many researchers calculate biomass yield from batch data. Strictly, this is the observed yield, $Y_{X/S}^{OBS}$. However, at high growth rates $Y_{X/S}^{OBS} \rightarrow Y_{X/S}$

Pirt plot seems to be preferred linearization.

5. More on maintenance

For *E. coli* on glucose:

$$m_S = 0.047 - 0.067 \text{ g gluc/gh} \approx \underline{\underline{0.05 \text{ g gluc/gh}}}$$

$$m_O = \underline{\underline{0.014 \text{ g O}_2\text{/gh}}}$$

$$Y_{X/S} = 0.422 - 0.455 \text{ g/g gluc} \approx \underline{\underline{0.44 \text{ g/g gluc}}}$$

$$Y_{X/O} = \underline{\underline{1.87 \text{ g/g O}_2}}$$

Farmer and Jones, 1976

Neijssel et al., 1996

Nanchen et al., 2006

Then
$$\frac{D}{Y_{X/S}^{OBS}} = m_s + \frac{D}{Y_{X/S}}$$

Becomes:
$$\frac{D}{Y_{X/S}^{OBS}} = 0.05 + \frac{D}{0.44}$$

D	$Y_{X/S}^{OBS}$	
0.05	0.306	Assuming maintenance is constant...
0.10	0.361	
0.20	0.396	
0.40	0.417	
0.80	0.428	

What is maintenance?

Protein turnover in *E. coli* during stationary phase is 5% per hour (Mandelstam & McQuillen, 1968). On the basis of a cell composition of 50% protein, 4 ATP needed per amino acid residue, an average molecular mass of an amino acid of 100, and 24 ATP generated per mole glucose, the glucose consumption rate necessary to sustain protein turnover is:

$$\frac{0.05}{h} \frac{0.5 \text{ g protein}}{\text{g cells}} \frac{4 \text{ mol ATP}}{\text{mol Amino Acid}} \frac{\text{mol AA}}{100 \text{ g AA}}$$

$$\frac{\text{mol glucose}}{24 \text{ mol ATP}} \frac{180 \text{ g glucose}}{\text{mol glucose}} = \underline{\underline{0.0076 \text{ g glucose/gh}}}$$

What is maintenance?

0.0076 g glucose/gh is 15% of 0.05 g glucose/gh. One could conclude that 15% of cell maintenance is due to protein turnover.

More than 50% of maintenance is proposed to be used to sustain a membrane potential (Stouthamer & Bettenhausen, 1977)

6. Product $DP = r_p$

We'll just write $r_p = q_p X$

So, $DP = q_p X$

7. Calculating substrate concentration in chemostat

We have previously shown that $D = \mu$ at steady-state.

But, several models exist for the relationship between specific growth rate μ and substrate concentration. For example, Monod model:

$$\mu = \frac{\mu_{\text{MAX}} S}{K_S + S}$$

Thus, at steady-state (“SS”) we would expect:

$$D = \frac{\mu_{\text{MAX}} S_{\text{SS}}}{K_S + S_{\text{SS}}}$$

Or:

$$S_{\text{SS}} = \frac{DK_S}{\mu_{\text{MAX}} - D}$$

This equation allows us to calculate the steady-state concentration of the substrate S for any dilution rate. Surprisingly, this equation states that the outlet substrate concentration is independent of the inlet substrate concentration! (as long as $S_{\text{IN}} > S_{\text{SS}}$).

Note that (unreasonably) $S_{\text{SS}} \rightarrow \infty$ as $D \rightarrow \mu_{\text{MAX}}$

What is steady-state substrate concentration?

For *E. coli* on glucose:

$$K_S = 9.2 \text{ mg/L} - 14.3 \text{ mg/L} \approx \underline{\underline{10 \text{ mg/L}}}$$

(Reiling et al. 1985)

$$\mu_{\text{MAX}} = 0.80 \text{ h}^{-1}$$

At a dilution rate of 0.40 h^{-1} :

$$S_{\text{SS}} = \frac{DK_S}{\mu_{\text{MAX}} - D} = \frac{(0.40 \text{ h}^{-1})(10 \text{ mg/L})}{(0.80 \text{ h}^{-1} - 0.40 \text{ h}^{-1})} = \underline{\underline{10 \text{ mg/L}}}$$

This value is very low. Thus, during a chemostat operation, there is essentially no substrate remaining in culture and in outlet. (i.e., growth rate is **limited** by the availability of substrate.) However, as the dilution rate increases, the steady-state concentration of this substrate increases, which changes which enzymes are induced by the substrate.

8. Calculating biomass concentration in chemostat

From the substrate balance we obtained:

$$\frac{D(S_{\text{IN}} - S)}{X} = m_S + \frac{D}{Y_{X/S}}$$

We found the steady-state substrate concentration:

$$S_{\text{SS}} = \frac{DK_S}{\mu_{\text{MAX}} - D}$$

We can therefore directly estimate the steady-state biomass concentration:

$$X_{SS} = \frac{D \left[S_{IN} - \frac{DK_S}{\mu_{MAX} - D} \right]}{m_S + \frac{D}{Y_{X/S}}}$$

Note that usually $S_{SS} \ll S_{IN}$. So,

$$X_{SS} \approx \frac{S_{IN}}{\frac{m_S}{D} + \frac{1}{Y_{X/S}}}$$

$$X_{SS} \approx \frac{S_{IN}}{\frac{m_S}{D} + \frac{1}{Y_{X/S}}}$$

$D \rightarrow 0$ ($D \ll m_S$), $X_{SS} \rightarrow 0$

$D \gg m_S$, $X_{SS} \rightarrow S_{IN} Y_{X/S}$
 (Note as $D \rightarrow \mu_{MAX}$, $S_{SS} \rightarrow S_{IN}$
 and equation is not valid)

9. Calculating Monod constant, K_S

$$S_{SS} = \frac{DK_S}{\mu_{MAX} - D}$$

This equation can also be used to calculate the parameters K_S and μ_{MAX} . These parameters are calculated by running several chemostats at different dilution rates and measuring the substrate concentration in the effluent. For example, rewrite this equation as...

$$\frac{1}{D} = \frac{K_S}{\mu_{MAX}} \frac{1}{S_{SS}} + \frac{1}{\mu_{MAX}}$$

$$y = mx + b$$

Plot $\frac{1}{S_{SS}}$ ("x") versus $\frac{1}{D}$ ("y")

$$\text{Intercept} = \frac{1}{\mu_{MAX}}$$

$$\text{Slope} = \frac{K_S}{\mu_{MAX}}$$

The slope is actually close to zero because K_S is so small.

10. Industrial use of a chemostat

Disadvantages:

- Product is diluted by all that feed; product never gets a chance to accumulate.
- Contamination is fatal. Because system is open and longer-lasting, it is also more subject to contamination.
- Evolution. The desired characteristics of a microbe can be lost if they don't confer an evolutionary advantage.

So, when would a chemostat be used?

- When product concentration is not relevant, or diluted product is desirable.
- When contamination is desirable.
- When evolution/selection of characteristics is desirable.

Specifically:

1. Wastewater Treatment
2. Biomining

11. Why conduct a laboratory chemostat experiment?

- To vary growth rate with no other change in the environment.
- To fix growth rate while changing the environment.
- To maintain substrate-limited growth with a constant growth rate.
- To determine the best growth rate to operate a fed-batch process.

11. Why conduct a laboratory chemostat experiment? (cont'd)

- To determine how product is formed relative to substrate consumption. (e.g., is product positively growth associated, negatively growth associated, etc.)
- To study evolution at a reasonable time-scale. Or, to intentionally evolve a strain for desired characteristics.
- To measure physiological fluxes.
- To affect metabolism in cases where a particular substrate limitation is advantageous.

12. Example calculations

Data Collected from Acetate-Limited Chemostat (Strain requires both glucose and acetate for growth)

Feed Flowrate	0.155 L/h
Volume	1.00 L
Gas Flowrate (STP)	1.00 L/min
Dry Cell Weight Concentration	2.45 g/L
<u>Feed Concentrations:</u>	
Glucose	35.494 g/L
Acetate	1.023 g/L
Pyruvate	0.000 g/L
O ₂ (Dry Basis)	20.92 %
CO ₂ (Dry Basis)	0.00 %
<u>Effluent Concentrations</u>	
Glucose	10.330 g/L
Acetate	0.000 g/L
Pyruvate	17.892 g/L
O ₂ (Dry Basis)	20.13 %
CO ₂ (Dry Basis)	0.67 %

a) Dilution Rate

$$D = \frac{F}{V}$$

$$D = \frac{0.155 \text{ L/h}}{1.00 \text{ L}} = \underline{\underline{0.155 \text{ h}^{-1}}}$$

b) Residence Time

$$\theta = \frac{1}{D} = \frac{1}{0.155 \text{ h}^{-1}} = \underline{\underline{6.45 \text{ h}}}$$

One should allow 4-5 residence times to pass before the system is “at” steady-state, so for this process at least 26 hours is needed to reach steady-state.

c) Observed Biomass Yield on Glucose

$$Y_{X/G}^{\text{OBS}} = \frac{X}{(G_{\text{IN}} - G)} = \frac{2.45 \text{ g/L}}{(35.494 - 10.330) \text{ g/L}}$$
$$= \underline{0.097 \text{ g cells/ g glucose}}$$

Probably makes more sense to calculate biomass yield on acetate, since it is **the** limiting substrate.

d) Observed Biomass Yield on Acetate

$$Y_{X/A}^{\text{OBS}} = \frac{X}{(A_{\text{IN}} - A)} = \frac{2.45 \text{ g/L}}{(1.023 - 0.0) \text{ g/L}}$$
$$= \underline{2.392 \text{ g cells/ g acetate}}$$

e) Volumetric Rate of Glucose Consumption

$$Q_G = (G_{\text{IN}} - G) \times D = (35.494 - 10.330) \text{ g/L} \times 0.155 \text{ h}^{-1}$$
$$= \underline{3.90 \text{ g glucose/Lh}}$$

f) Specific Rate of Glucose Consumption

$$q_G = \frac{Q_G}{X} = \frac{3.90 \text{ g/Lh}}{2.45 \text{ g/L}}$$
$$= \underline{1.59 \text{ g glucose/g cells h}}$$

Note: An interesting calculation can be made from the value of q_G :

$$\begin{aligned} & \frac{1.59 \text{ g gluc}}{\text{g cells h}} \times \frac{\text{mol gluc}}{180 \text{ g gluc}} \times \frac{6.02 \times 10^{23} \text{ mlcs}}{\text{mol}} \\ & \times \frac{2 \times 10^{-13} \text{ g cells}}{\text{cell}} \times \frac{\text{h}}{3600 \text{ s}} \\ & = \underline{296,000 \text{ mlcs glucose/second (per cell)}} \end{aligned}$$

g) Volumetric Rate of Pyruvate Production

$$\begin{aligned} Q_P &= (P - P_{IN}) \times D = (17.892 - 0.0) \text{ g/L} \times 0.155 \text{ h}^{-1} \\ &= \underline{2.77 \text{ g pyruvate/Lh}} \end{aligned}$$

h) Specific Rate of Pyruvate Production

$$\begin{aligned} q_P &= \frac{Q_P}{X} = \frac{2.77 \text{ g/Lh}}{2.45 \text{ g/L}} \\ &= \underline{1.13 \text{ g pyruvate/g cells h}} \end{aligned}$$

i) Oxygen

The gas composition is at STP and is dry basis. Thus, the only components of the gas are N_2 , O_2 , & CO_2 .

Inlet:

$$x_N + x_O + x_{CO_2} = 1$$

$$x_N + 0.2092 + 0 = 1$$

$$x_N = 0.7908$$

$$n_{TOTAL}^{IN} = \frac{PQ_{GAS}}{RT} = \frac{(1000)(1 \text{ atm})(1.00 \text{ L/min})}{(0.08206 \text{ L atm/molK})(273.15K)}$$

i) Oxygen (cont'd)

$$n_{TOTAL}^{IN} = 44.61 \text{ mmol/min}$$

$$n_N^{IN} = (0.7908)(44.61) = 35.28 \text{ mmol/min}$$

$$n_O^{IN} = (0.2092)(44.61) = 9.33 \text{ mmol/min}$$

Outlet:

$$x_N + x_O + x_{CO_2} = 1$$

$$x_N + 0.2013 + 0.0067 = 1$$

$$x_N = 0.7920 \quad n_N^{IN} = n_N^{OUT} = 35.28 \text{ mmol/min}$$

i) Oxygen (cont'd)

$$n_{\text{TOTAL}}^{\text{OUT}} = n_{\text{N}}^{\text{OUT}} / x_{\text{N}} = 35.28/0.7920 = 44.55 \text{ mmol/min}$$

$$n_{\text{O}}^{\text{OUT}} = (0.2013)(44.55) = 8.97 \text{ mmol/min}$$

$$n_{\text{CO}_2}^{\text{OUT}} = (0.0067)(44.55) = 0.30 \text{ mmol/min}$$

$$\begin{aligned} \text{OUR} &= (n_{\text{O}}^{\text{IN}} - n_{\text{O}}^{\text{OUT}}) / V = [(9.33 - 8.97) \text{ mmol/min}] / 1.00 \text{ L} \\ &= 0.36 \text{ mmol/Lmin} = \underline{21.96 \text{ mmol/Lh}} \end{aligned}$$

$$q_{\text{O}} = \text{OUR} / X = (21.96 \text{ mmol/Lh}) / (2.45 \text{ g/L}) = \underline{8.96 \text{ mmol/gh}}$$

j) Carbon Dioxide (CO₂ Evolution Rate, CER)

$$\text{CER} = (n_{\text{CO}_2}^{\text{OUT}} - n_{\text{CO}_2}^{\text{IN}}) / V = [(0.30 - 0.00) \text{ mmol/min}] / 1.00 \text{ L}$$

$$= 0.30 \text{ mmol/Lmin} = \underline{17.91 \text{ mmol/Lh}}$$

$$q_{\text{CO}_2} = \text{CER} / X = (17.91 \text{ mmol/Lh}) / (2.45 \text{ g/L}) = \underline{7.31 \text{ mmol/gh}}$$

k) RQ

The Respiratory Quotient (RQ) or Respiratory Coefficient is merely the molar ratio of CO₂ generated to O₂ consumed. It can also be calculated from the ratio of rates:

$$RQ = \frac{CER}{OUR}$$

$$RQ = \frac{17.91 \text{ mmol/Lh}}{21.96 \text{ mmol/Lh}} = 0.816 \text{ mol/mol}$$

Note that complete 'combustion' of glucose would result in an RQ of 1.00.

l) Carbon Balance

Carbon Generated

$$\begin{aligned} \text{CO}_2: & (17.91 \text{ mmol CO}_2/\text{Lh})(1.00 \text{ L})(1 \text{ mol C/mol CO}_2) \\ & = 17.91 \text{ mmol C/h} \end{aligned}$$

$$\begin{aligned} \text{Pyruvate:} & (2.77 \text{ g pyru/Lh})(\text{mol pyru}/87.06 \text{ g pyru}) \\ & (1.00 \text{ L})(1000 \text{ mmol/mol})(3 \text{ mol C/mol pyru}) \\ & = 95.45 \text{ mmol C/h} \end{aligned}$$

$$\begin{aligned} \text{Biomass:} & (2.45 \text{ g DCW/L})(0.155 \text{ h}^{-1})(1.00 \text{ L}) \\ & (\text{mol DCW}/24.70 \text{ g DCW}\dagger)(1000 \text{ mmol/mol}) \\ & (1 \text{ mol C/mol DCW}) \\ & = 15.37 \text{ mmol C/h} \end{aligned}$$

I) Carbon Balance (cont'd)

†Battley (1991, 2003) found apparent “unit carbon” molecular formula of *E. coli* to be:

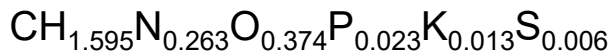

FW = 24.70 g DCW/mol

Notes:

A “unit carbon” formula has subscript of 1.00 for C.

% C by mass is 48.6%

% N by mass is 14.9%

% P by mass is 2.9%

I) Carbon Balance (cont'd)

Carbon Consumed

$$\begin{aligned} \text{Glucose: } & (3.90 \text{ g gluc/Lh})(\text{mol gluc}/180.16 \text{ g gluc}) \\ & (1.00 \text{ L})(1000 \text{ mmol/mol})(6 \text{ mol C/mol gluc}) \\ & = 129.88 \text{ mmol C/h} \end{aligned}$$

$$\begin{aligned} \text{Acetate: } & (1.023 - 0.000 \text{ g/L})(0.155 \text{ h}^{-1})(1.00 \text{ L}) \\ & (\text{mol acet}/59.05 \text{ g acet})(1000 \text{ mmol/mol}) \\ & (2 \text{ mol C/mol acet}) \\ & = 5.37 \text{ mmol C/h} \end{aligned}$$

I) Carbon Balance (cont'd)

Carbon Balance

$$\begin{aligned}\text{Total C Generated} &= 17.19 + 95.45 + 15.37 \\ &= 128.62 \text{ mmol C/h}\end{aligned}$$

$$\begin{aligned}\text{Total C Consumed} &= 129.88 + 5.37 \\ &= 135.3 \text{ mmol C/h}\end{aligned}$$

$$\begin{aligned}\text{Carbon Recovery} &= \frac{\text{Carbon Generated}}{\text{Carbon Consumed}} = \frac{128.62}{135.3} \\ &= \underline{95.1\%}\end{aligned}$$

13. How much time is required to reach steady-state?
(Assuming volume does not change)

This is an unsteady-state problem, so return to the differential equations:

a) Cells:
$$\frac{dX}{dt} = -DX + \mu X$$

b) Substrate:
$$\frac{dS}{dt} = D(S_{IN} - S) + r_S$$

Simplifications/Assumptions:

$$-r_S = m_S X + \frac{\mu X}{Y_{X/S}} + \frac{q_P X}{Y_{P/S}}$$

Again take the term $\frac{q_P X}{Y_{P/S}}$ to be small:

$$-r_S = m_S X + \frac{\mu X}{Y_{X/S}}$$

Assume Monod model relates specific growth rate μ and substrate concentration:

$$\mu = \frac{\mu_{MAX} S}{K_S + S}$$

So, the differential equations become:

$$\frac{dX}{dt} = -DX + \frac{\mu_{MAX} SX}{K_S + S}$$

$$\frac{dS}{dt} = D(S_{IN} - S) - m_S X - \frac{\mu_{MAX} SX}{Y_{X/S}(K_S + S)}$$

In order to solve these differential equations we need **initial conditions** and **values** for the various parameters and experimental conditions.

Parameters:

$$m_S = 0.05 \text{ g/gh}$$

$$K_S = 10 \text{ mg/L} = 0.01 \text{ g/L}$$

$$\mu_{\text{MAX}} = 0.80 \text{ h}^{-1}$$

$$Y_{X/S} = 0.44 \text{ g/g}$$

Experimental Conditions:

$$S_{\text{IN}} = 10 \text{ g/L}$$

$$D = 0.30 \text{ h}^{-1}$$

Simulated Initial Conditions: (Note $X_{\text{SS}} = 4.1 \text{ g/L}$ and $S_{\text{SS}} = 6 \text{ mg/L}$)

Case I: $X_0 = 0.1 \text{ g/L}$ $S_0 = 0.01 \text{ g/L}$

Case II: $X_0 = 0.1 \text{ g/L}$ $S_0 = 10 \text{ g/L}$

Case III: $X_0 = 5.0 \text{ g/L}$ $S_0 = 0.01 \text{ g/L}$

Case IV: $X_0 = 5.0 \text{ g/L}$ $S_0 = 10 \text{ g/L}$

Starts closest to steady-state

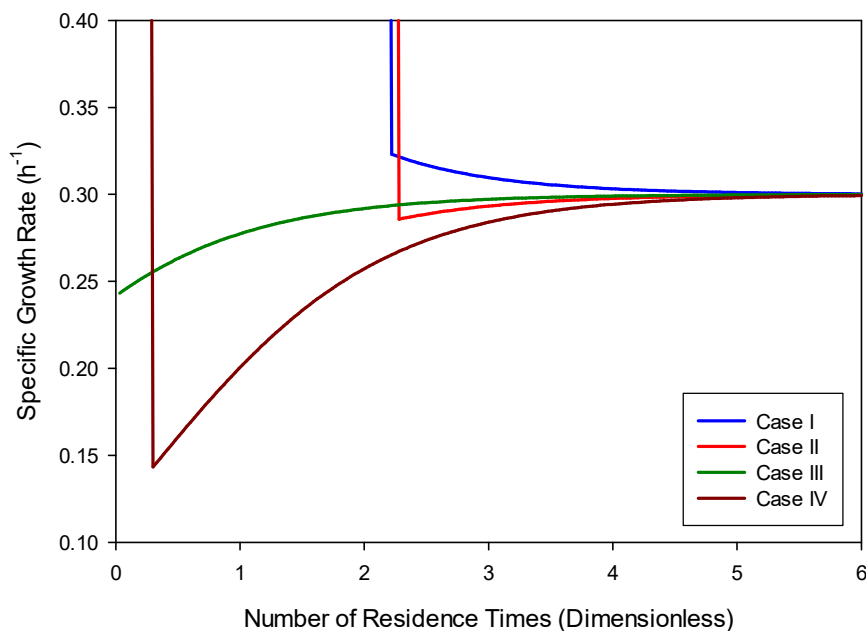

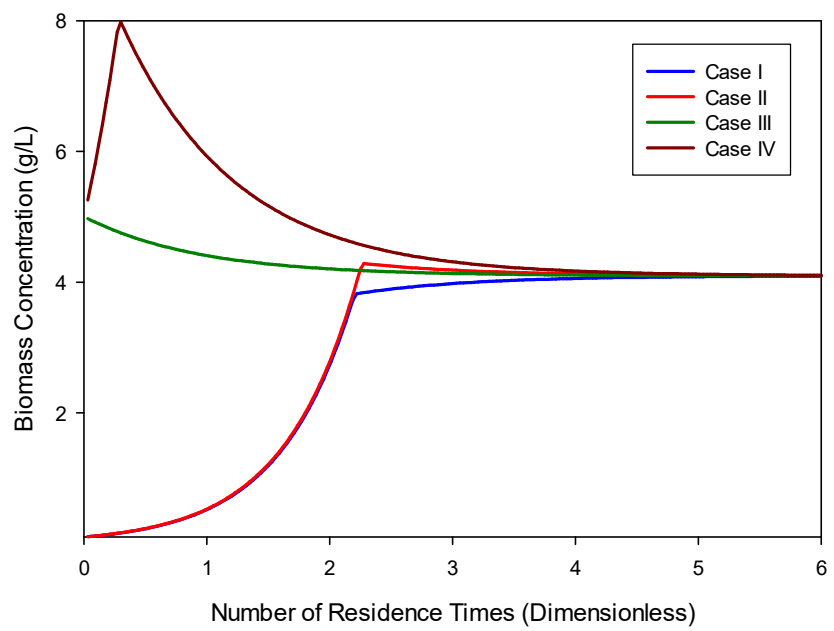
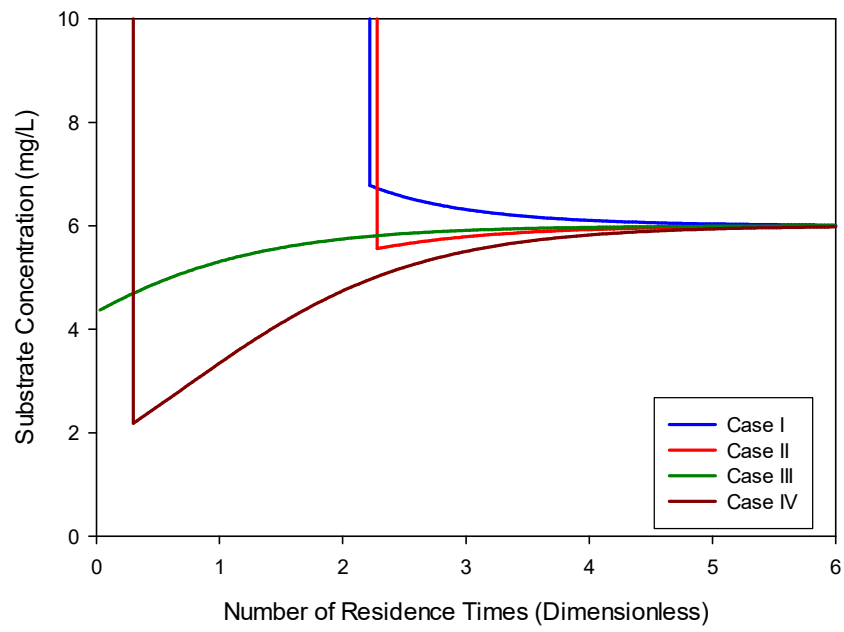

Summary:

Residence Time
to reach within 2%
of steady-state

	X	S	μ
Case I	3.33	3.87	3.42
Case II	3.06	3.54	3.09
Case III	2.22	2.73	2.28
Case IV	3.90	4.38	3.93

Conclusions:

- The closer the cell concentration to the steady-state concentration, the faster the approach to steady-state.
- The closer the substrate concentration to the steady-state concentration (which is nearly zero!), the faster the approach to steady-state.
- This analysis does not indicate the amount of time required for the cells to achieve a physiological and genetic steady-state. (!)
- In practice a common recommendation for initiating a chemostat is to start with a batch process with $\frac{1}{2}$ of the concentration of the substrate planned for the ultimate feed. Just when the substrate is exhausted, initiate the feed and wait **4-5 residence times**.

14. Competition

In a bioreactor supplied a single substrate (energy source), two different microbial species will compete for that single substrate. Similarly, two different variants of the same species (e.g., one with a plasmid/one without a plasmid or a variant generated by a random mutation) will compete for that single substrate. In a chemostat, differences between two strains become magnified by the extended duration of the system.

Concentration of organism #1: X'
 Parameters: $m_S', K_S', \mu_{MAX}', Y_{X/S}'$

Concentration of organism #2: X''
 Parameters: $m_S'', K_S'', \mu_{MAX}'', Y_{X/S}''$

So, the differential equations become:

$$\frac{dX'}{dt} = -DX' + \frac{\mu_{MAX}'SX'}{K_S' + S}$$

$$\frac{dX''}{dt} = -DX'' + \frac{\mu_{MAX}''SX''}{K_S'' + S}$$

$$\begin{aligned} \frac{dS}{dt} = D(S_{IN} - S) &- m_S'X' - \frac{\mu_{MAX}'SX'}{Y_{X/S}'(K_S' + S)} \\ &- m_S''X'' - \frac{\mu_{MAX}''SX''}{Y_{X/S}''(K_S'' + S)} \end{aligned}$$

Note:

A change in either K_S' or μ_{MAX}' (to K_S'' or μ_{MAX}'') will affect the values of X' and X'' .

The parameters m_S' or $Y_{X/S}'$ appear in the differential equation for the substrate concentration (S). These parameters do not separately, directly affect values of X' and X'' .

There is only one substrate concentration (S), but two strains contribute to its consumption.

Parameters:

$$m_S = 0.05 \text{ g/gh}$$

$$K_S = 10 \text{ mg/L} = 0.01 \text{ g/L}$$

$$\mu_{\text{MAX}} = 0.80 \text{ h}^{-1}$$

$$Y_{X/S} = 0.44 \text{ g/g}$$

Experimental Conditions:

$$S_{\text{IN}} = 5 \text{ g/L}$$

Initial Conditions:

$$D_0 = 0.30 \text{ h}^{-1}$$

$$X_0 = 2.047 \text{ g/L (steady-state at } D = 0.30 \text{ h}^{-1}\text{)}$$

$$S_0 = 6.00 \text{ mg/L (steady-state at } D = 0.30 \text{ h}^{-1}\text{)}$$

Simulated Cases:

Case I:

at $t = 5 \text{ h}$ (1.5 RT), a new strain appears with **10% lower K_S** .

	original strain (')	competitor ('')	
X	2.046	0.001	g/L
m_S	0.05	0.05	g/gh
K_S	0.010	0.009	g/L
μ_{MAX}	0.80	0.80	h^{-1}
$Y_{X/S}$	0.44	0.44	g/g

$$\mu = \frac{\mu_{\text{MAX}} S}{K_S + S} \quad \mu' = \frac{(0.80)(6.0)}{10.0 + 6.0} = \underline{0.30 \text{ h}^{-1}} \quad \mu'' = \frac{(0.80)(6.0)}{9.0 + 6.0} = \underline{0.32 \text{ h}^{-1}}$$

Case I: 10% lower K_S .

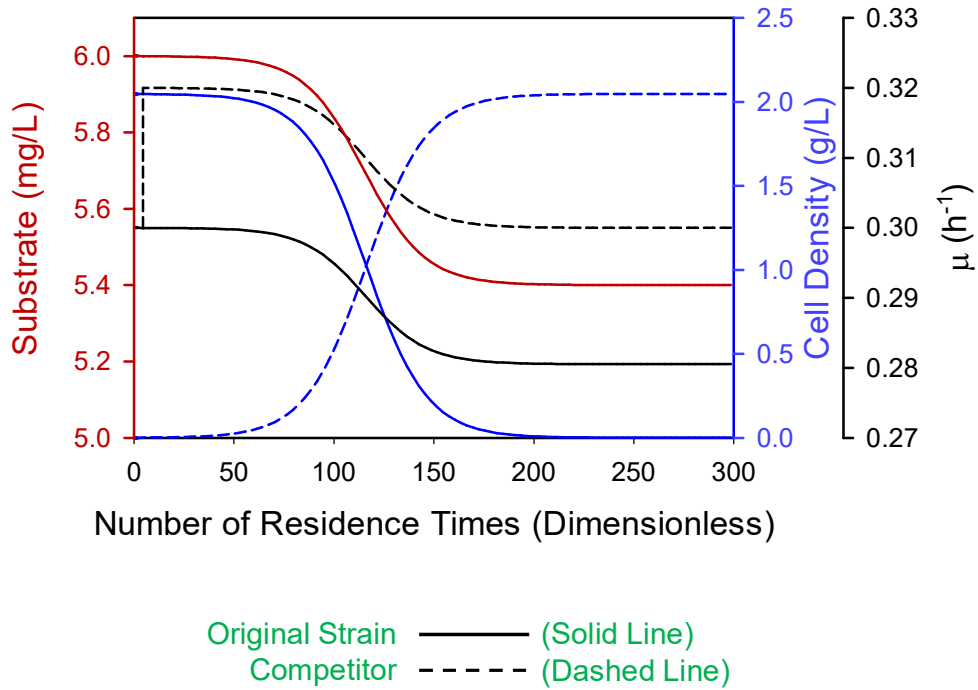

Case II:

at $t = 5$ h (1.5 RT), a new strain appears with **6.7% greater μ_{MAX}** .

	original strain (')	competitor ('')	
X	2.046	0.001	g/L
m_s	0.05	0.05	g/gh
K_S	0.010	0.010	g/L
μ_{MAX}	0.80	0.853	h^{-1}
$Y_{X/S}$	0.44	0.44	g/g

$$\mu = \frac{\mu_{MAX} S}{K_S + S} \quad \mu' = \frac{(0.80)(6.0)}{10.0 + 6.0} = 0.30 \text{ h}^{-1} \quad \mu'' = \frac{(0.853)(6.0)}{10.0 + 6.0} = 0.32 \text{ h}^{-1}$$

Case II: 6.7% greater μ_{MAX} .

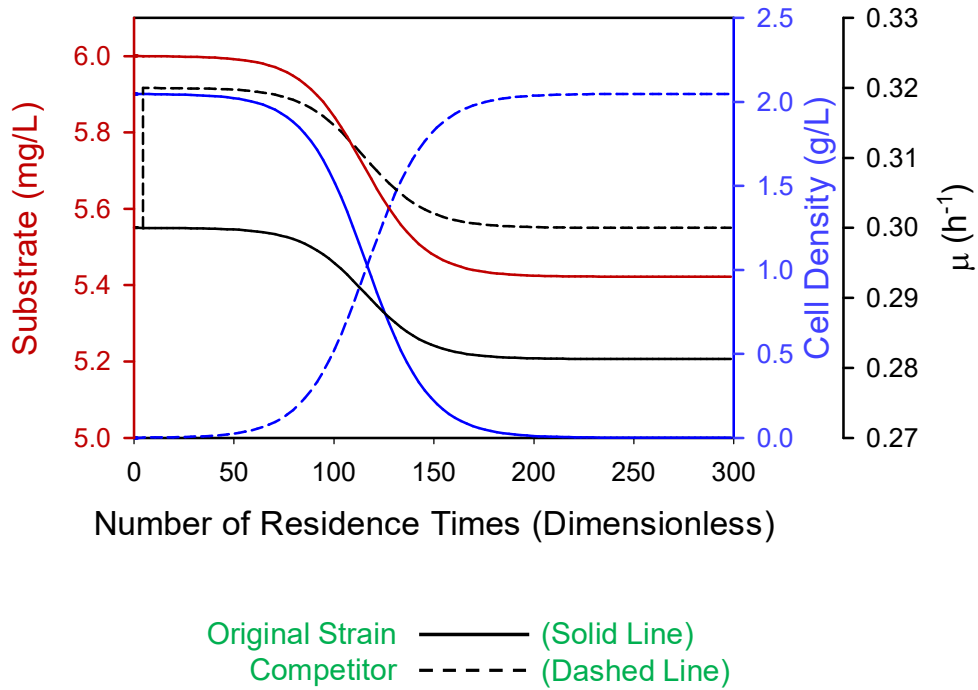

Case III:

at $t = 5 \text{ h}$ (1.5 RT), a new strain appears with **10% lower m_S** .

	original strain (')	competitor ('')	
X	2.046	0.001	g/L
m_S	0.05	0.045	g/gh
K_S	0.010	0.010	g/L
μ_{MAX}	0.80	0.80	h^{-1}
$Y_{X/S}$	0.44	0.44	g/g

Does not directly alter specific growth rate.

Case III: 10% lower m_S .

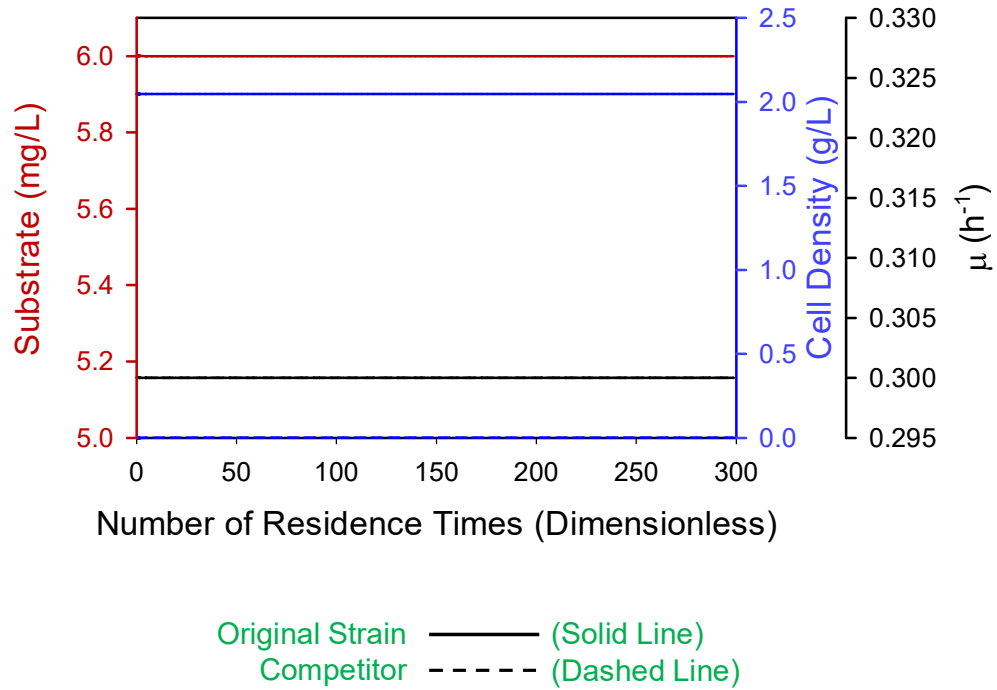

Case IV:

at $t = 5$ h (1.5 RT), a new strain appears with **10% greater $Y_{X/S}$** .

	original strain (')	competitor ('')	
X	2.046	0.001	g/L
m_S	0.05	0.05	g/gh
K_S	0.010	0.010	g/L
μ_{MAX}	0.80	0.80	h^{-1}
$Y_{X/S}$	0.44	0.484	g/g

Does not directly alter specific growth rate.

Case IV: 10% greater $Y_{X/S}$.

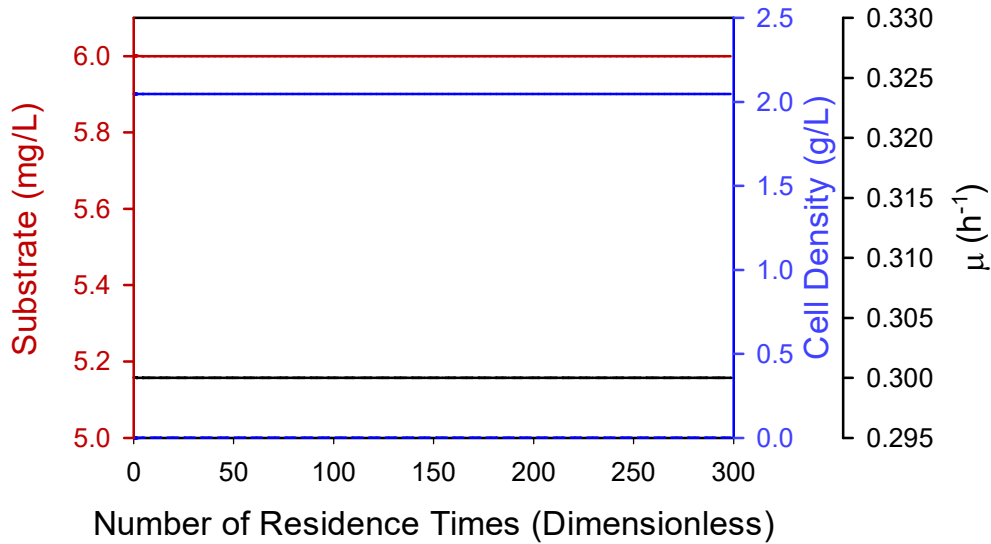

What does a change in m_s or $Y_{X/S}$ do?:

$$\frac{dX'}{dt} = -DX' + \frac{\mu_{MAX}'SX'}{K_S' + S}$$

$$\frac{dX''}{dt} = -DX'' + \frac{\mu_{MAX}''SX''}{K_S'' + S}$$

$$\frac{dS}{dt} = D(S_{IN} - S) \uparrow \downarrow m_s'X' - \frac{\mu_{MAX}'SX'}{Y_{X/S}'(K_S' + S)} \uparrow$$

$$\downarrow m_s''X'' - \frac{\mu_{MAX}''SX''}{Y_{X/S}''(K_S'' + S)} \uparrow$$

Decrease in m_s or increase in $Y_{X/S}$?

Increases the steady-state substrate concentration. This change is more pronounced if S_{IN} is low.

Very slightly increases growth rate of both strains.

Which is going to decrease steady-state substrate concentration...net result is no change.

Conclusions:

- The introduction of a competitor with decreased K_S or increased μ_{MAX} will lead to that competitor taking over the culture.
- The introduction of a competitor with decreased m_S or increased $Y_{X/S}$ will lead to no change in the culture. That competitor can stably co-exist with the original strain.
- This analysis relies on the *empirical* Monod model.
- This analysis considers a competitor with only a single difference from the original strain. Typically, a competitor has multiple differences.
- Analysis has relevance to protein expression (which reduces growth rate) and evolution.

15. Other thoughts

a) What does “maximum growth rate” really mean?

Maximum specific growth rate measured in batch typically does not correspond with maximum dilution rate or wash-out observed in a chemostat.

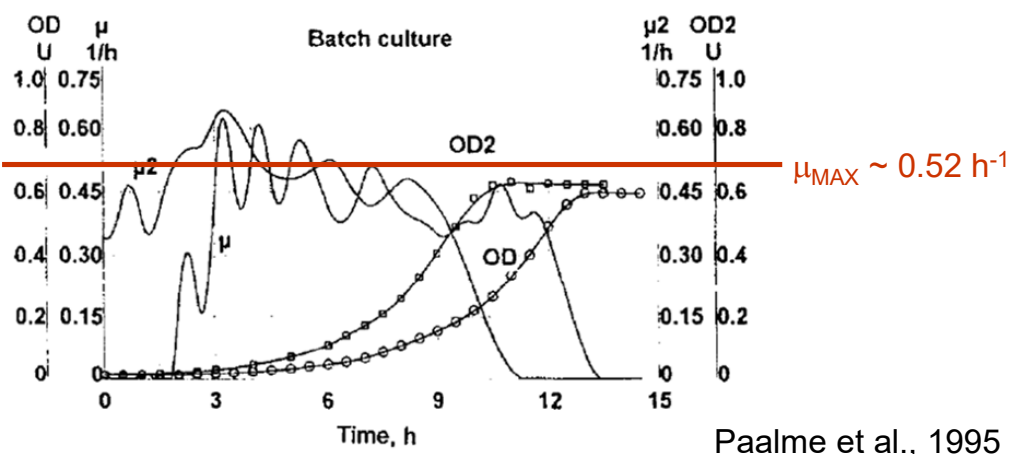

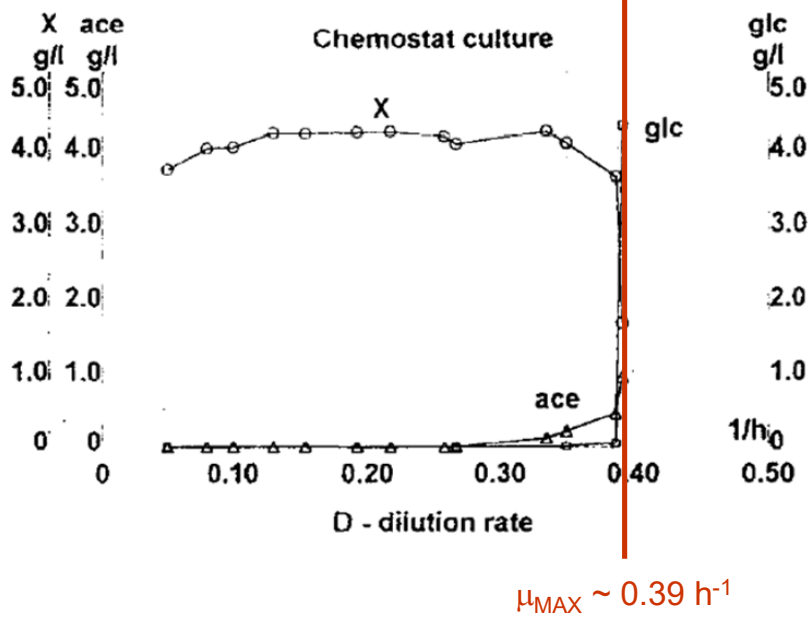

Paalme et al., 1995

In a batch culture, the maximum specific growth rate is measured before the inhibitor (acetate) was formed.

In a continuous chemostat culture, because it is at steady-state, the maximum specific growth rate is measured in the presence of the inhibitor.

The specific growth rate measured is the growth rate attained by the cells in **that** particular environment (e.g., presence of inhibitor compared to absence of inhibitor).

b) Practical matters for conducting chemostat experiments

i) Maintaining a constant volume

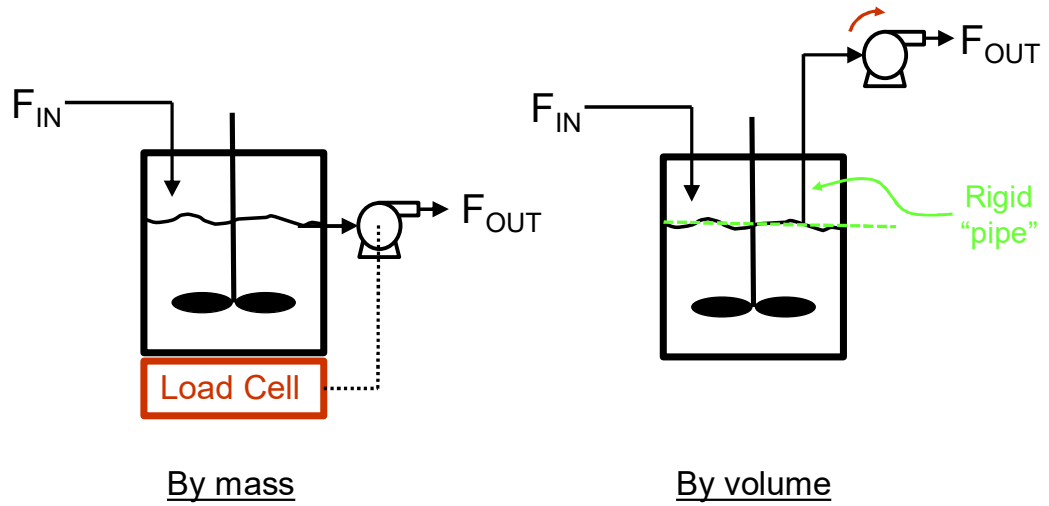

ii) Hold-up volume

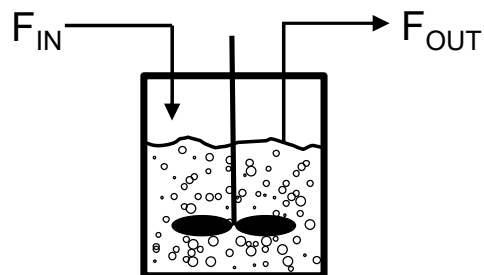

$$\text{Volume of liquid} = \text{Total volume of contents} - \text{Volume of gas}$$

iii) Controlling feed rate

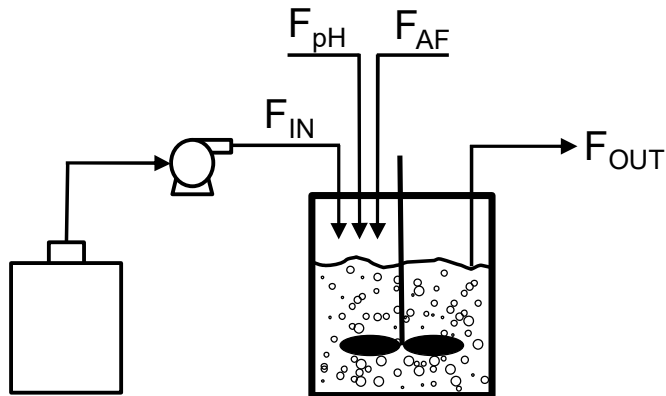

True feed rate (F_{TRUE}) =

Nutrient Feed (F_{IN}) + Feed of base/acid (F_{pH}) + Feed of anti-foam (F_{AF}) + etc.

Best approach is to have nutrient feed itself control pH and foam.

iv) Avoid contamination (e.g., of nutrient reservoir, etc.)

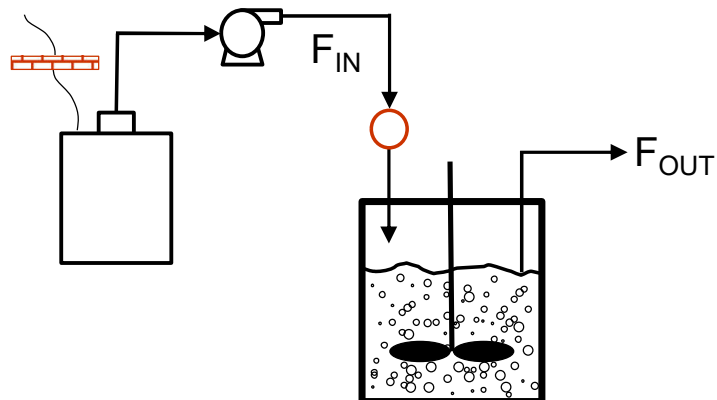

- Add “glass bubbles” as air trap for nutrient feed.
- Displace volume with filtered air.

v) What experimental conditions should be selected?

a) Lower substrate concentration?

- less cost of (all) nutrients
- lower O_2 demand
- less cells
- less O_2 consumed and CO_2 generated, so measurement of O_2 and CO_2 must be more sensitive.

Note that, according to Monod model, changing inlet concentration S_{IN} changes X_{SS} but not S_{SS}

a) Lower inlet O_2 flow rate?

- lower cost for gases
- O_2 consumption and CO_2 generation has a greater impact on changing O_2 and CO_2 composition of exiting gas...more accurate measurement of O_2 and CO_2 .
- more likely to become O_2 limited.

c) Lower reactor volume?

- lower cost for medium
- less O_2 consumed and CO_2 generated, so measurement of O_2 and CO_2 must be more sensitive.

vi) Wall growth

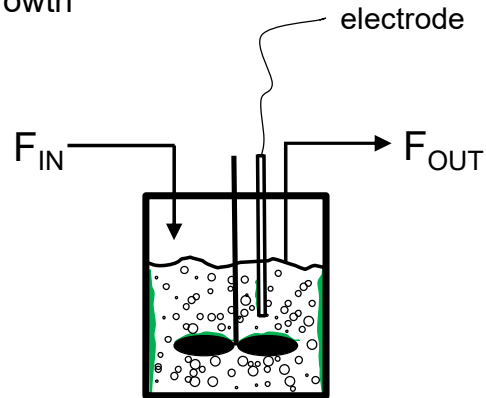

Most organisms have mechanisms to attach themselves to surfaces. “Wall growth” increases effective cell density and changes physiology of cells.

Keep experiments short or use coatings on surfaces.

F. Accelerostat

1. Motivations

When a dilution rate D is set, the system will reach a steady-state. Changing the dilution rate to a new set point will introduce a perturbation which will eventually ‘dampen out’, allowing the system to reach a new steady-state.

The unsteady-state analysis in §E.13 suggests that we need to wait 4-5 residence times between steady-states. Thus, measuring multiple steady-states would seem to take a lot of time!

A **pseudo-steady state** is when the change between two steady-state conditions happens very slowly, so slowly that the system never significantly deviates from steady-state.

For example, instead of changing abruptly from a steady-state $D = 0.15 \text{ h}^{-1}$ to a new $D = 0.30 \text{ h}^{-1}$, what if the system changes from $D = 0.15 \text{ h}^{-1}$ to $D = 0.16 \text{ h}^{-1}$ over the course of an hour?

In other words, in this example, $\frac{dD}{dt} = 0.01 \text{ h}^{-2}$

What if the system changes from $D = 0.15 \text{ h}^{-1}$ to $D = 0.16 \text{ h}^{-1}$ over the course of five hours?

In other words, in this example, $\frac{dD}{dt} = 0.002 \text{ h}^{-2}$

2. Simulation

Repeat unsteady-state simulation as before:

$$\frac{dX}{dt} = -DX + \frac{\mu_{\text{MAX}}SX}{K_S + S}$$

$$\frac{dS}{dt} = D(S_{\text{IN}} - S) - m_S X - \frac{\mu_{\text{MAX}}SX}{Y_{X/S}(K_S + S)}$$

$$\frac{dD}{dt} = K$$

We will start this simulation at a steady-state of $D = 0.05 \text{ h}^{-1}$ which is our initial value for the third differential equation.

Parameters:

$m_S = 0.05 \text{ g/gh}$
 $K_S = 10 \text{ mg/L} = 0.01 \text{ g/L}$
 $\mu_{MAX} = 0.80 \text{ h}^{-1}$
 $Y_{X/S} = 0.44 \text{ g/g}$

Experimental Conditions:

$S_{IN} = 5 \text{ g/L}$

Initial Conditions:

$D_0 = 0.05 \text{ h}^{-1}$
 $X_0 = 1.528 \text{ g/L}$ (steady-state at $D = 0.05 \text{ h}^{-1}$)
 $S_0 = 0.67 \text{ mg/L}$ (steady-state at $D = 0.05 \text{ h}^{-1}$)

Simulated Cases:

$0.05 \text{ h}^{-1} \rightarrow 0.40 \text{ h}^{-1}$

Case I:	$K = 0.002 \text{ h}^{-2}$	175 h
Case II:	$K = 0.01 \text{ h}^{-2}$	35 h
Case III:	$K = 0.02 \text{ h}^{-2}$	18 h

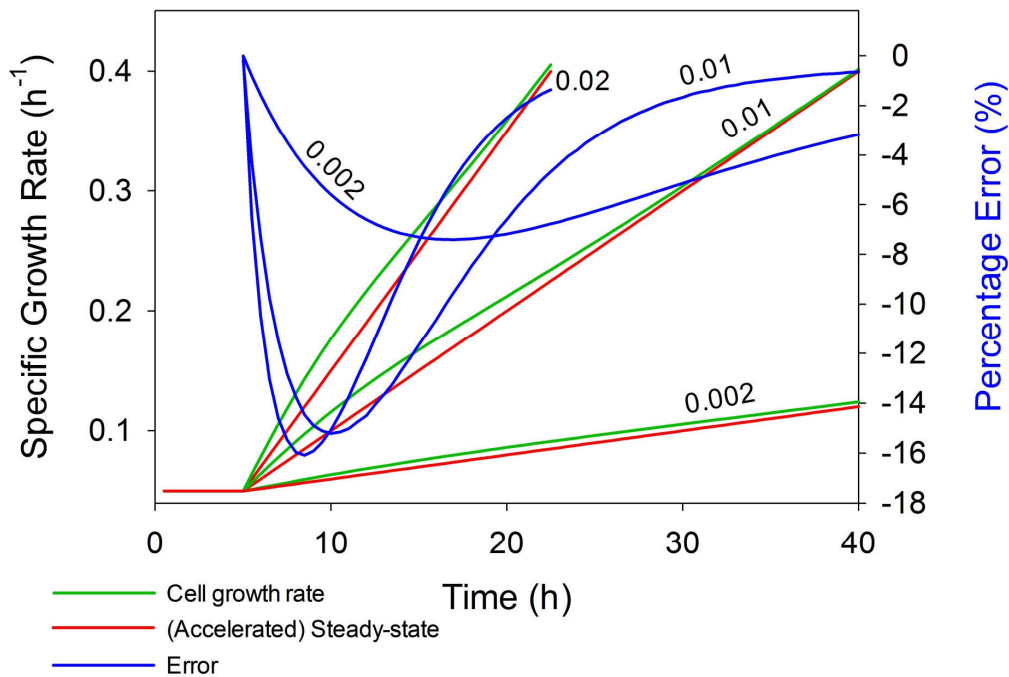

Conclusions:

- The lower the rate of acceleration, the closer the pseudo-steady state growth rate is to a steady-state.
- The lower the rate of acceleration, the more time is required for the process.

G. Physiological consequences of nutrient limitation

1. Introduction

The **growth limiting substrate** is the substrate which is consumed according to the intrinsic biological kinetics of the cells, and therefore it **controls** the cell growth. Simply put, the stoichiometry of cell growth dictates the quantity of energy and elements needed, and the growth limiting substrate is the nutrient exhausted (first) in the formation of cells. Note that other, non-limiting substrates are consumed at their maximal specific rate.

Often certain nutrients, particularly oxygen, can not be consumed faster than some maximum specific rate. Such a **respiratory capacity** can cause a cell to behave in a nutrient (oxygen)-limited way despite that nutrient being supplied in excess.

2. Respiratory capacity

At a **critical dilution rate**, cells can reach their respiratory capacity, and they are unable to consume oxygen any faster. More specifically, they have reached the maximum rate at which they can carry out the following (greatly simplified) reaction:

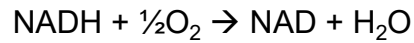

If the rate of NADH generation (from metabolism) increases beyond the maximum rate at which NADH can be oxidized by oxygen, then the cells must find another way to oxidize this NADH.

Respiratory capacity is quantified by the specific rate of oxygen consumption (q_{O} , mmol/gh).

Most researchers show a relationship between q_{O} and D because they set the dilution rate (independent variable) and measure the oxygen and substrate consumption. The real, physiological relationship is between q_{O} and the **specific rate of substrate (energy source) utilization, q_{S}** .

2. Respiratory capacity (in general)

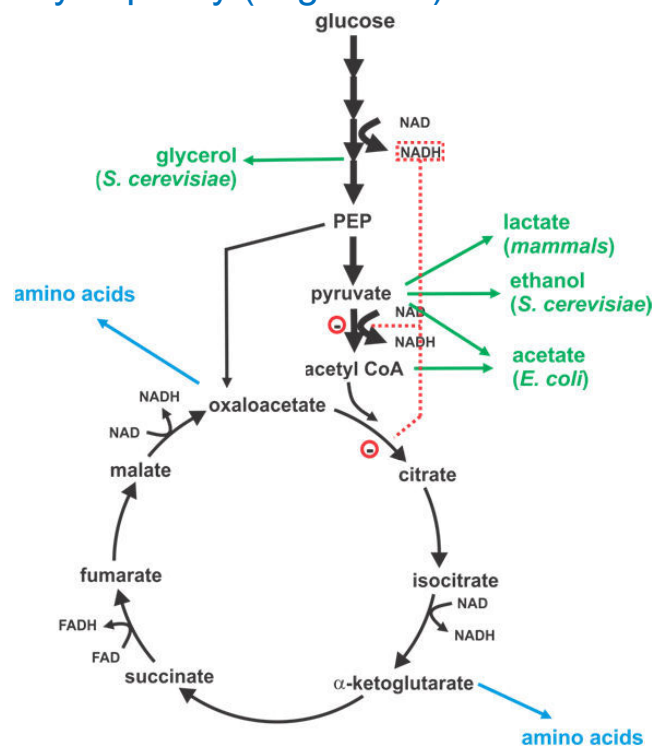

2. Respiratory capacity

Respiratory capacity is directly associated with **overflow metabolism**. For *E. coli*:

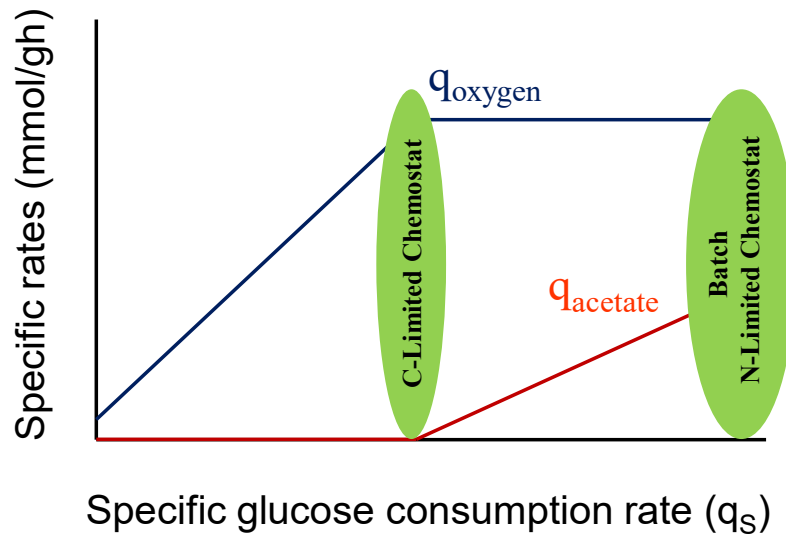

2. Respiratory capacity (in *S. cerevisiae*)

Steady-state (chemostat)

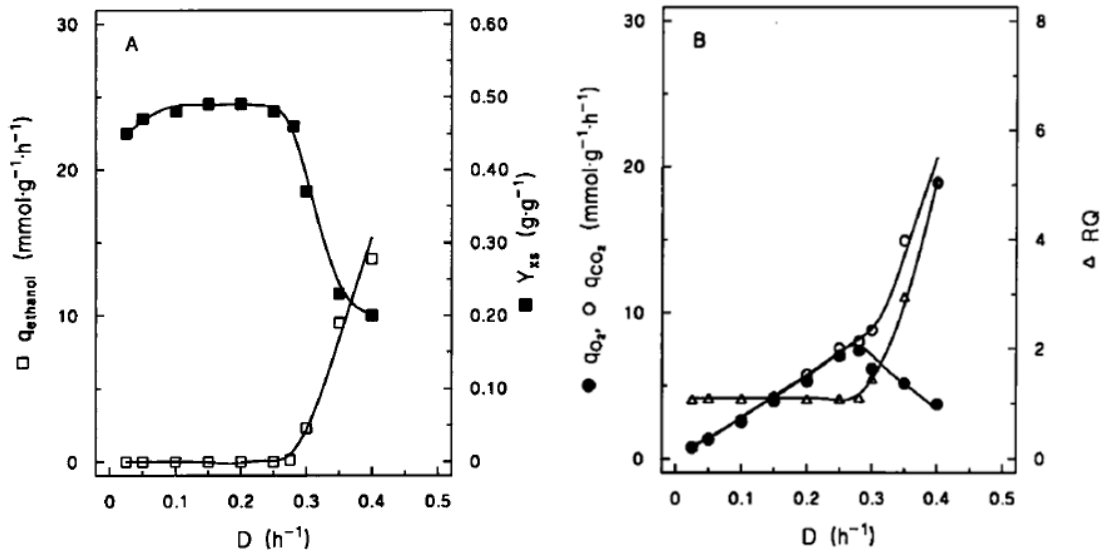

van Hoek et al., 1998

2. Respiratory capacity (in *E. coli*)

Steady-state (chemostat)

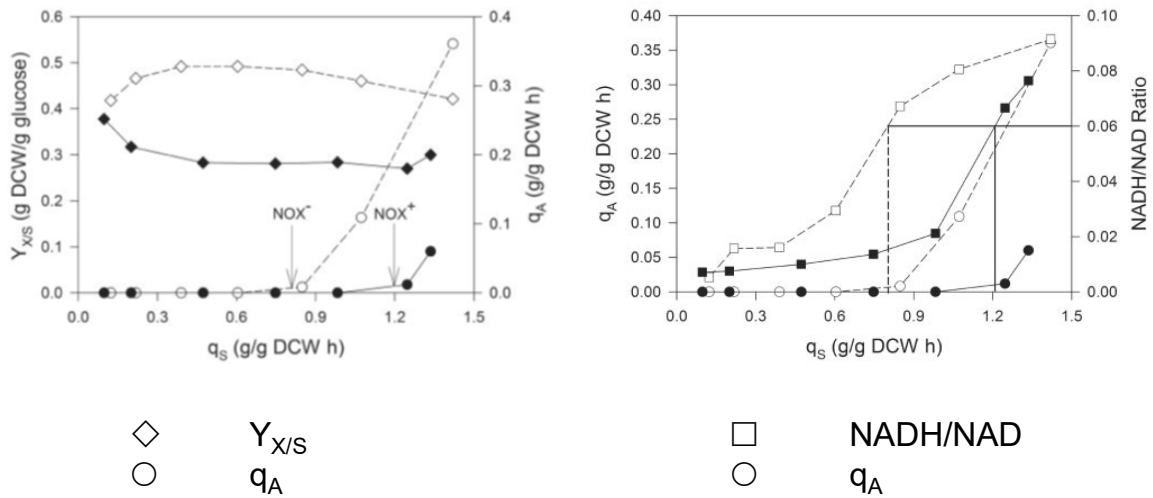

Vemuri et al., 2006

2. Respiratory capacity (in *E. coli*)

Steady-state (chemostat)

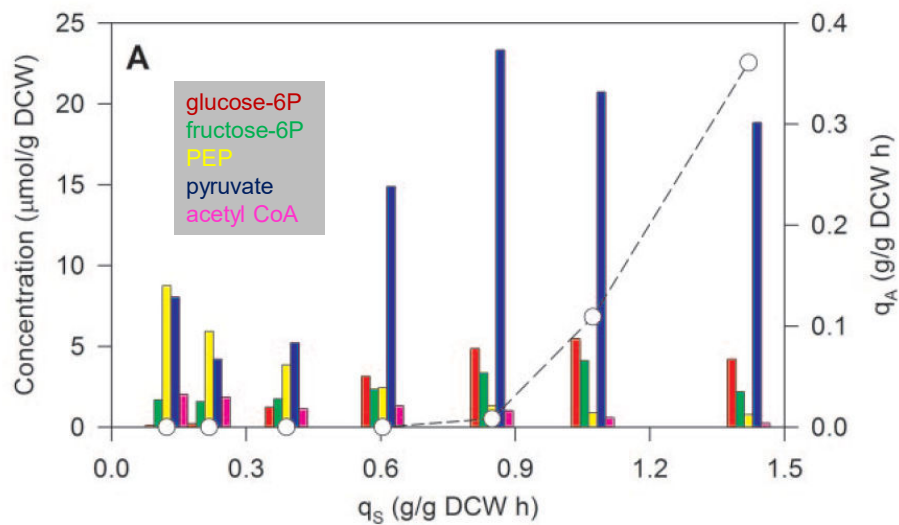

Vemuri et al., 2006

2. Respiratory capacity (in *E. coli*)

Steady-state (chemostat)

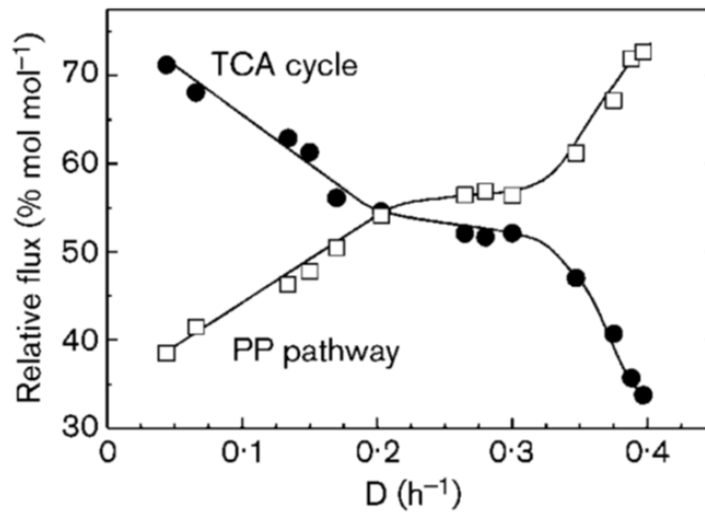

Kayser et al., 2005

2. Respiratory capacity (relieving accumulation of NADH)

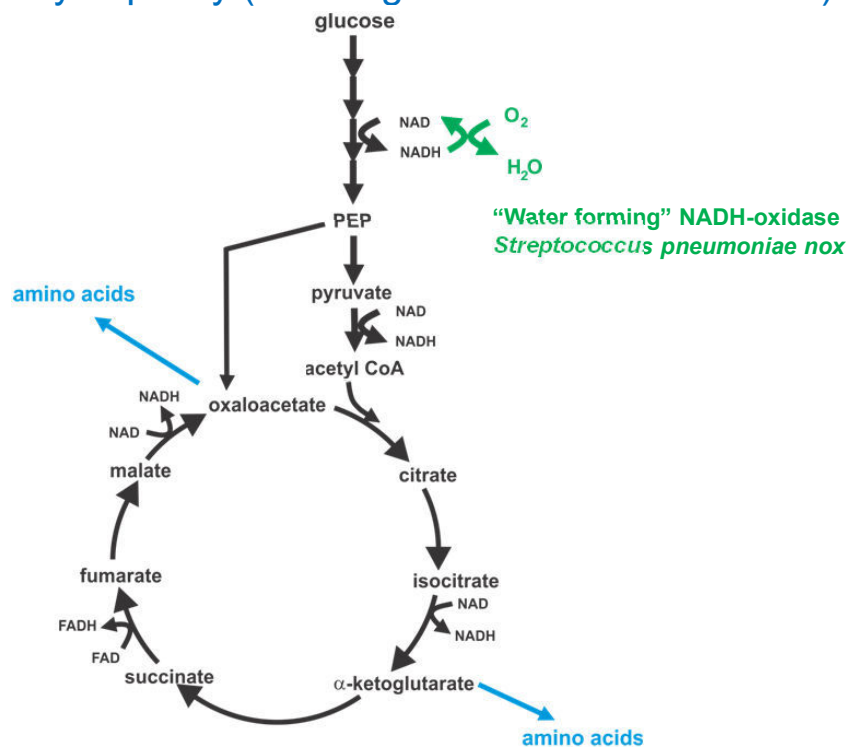

2. Respiratory capacity (in *E. coli* with *nox*)

Steady-state (chemostat)

Relieving accumulation of NADH

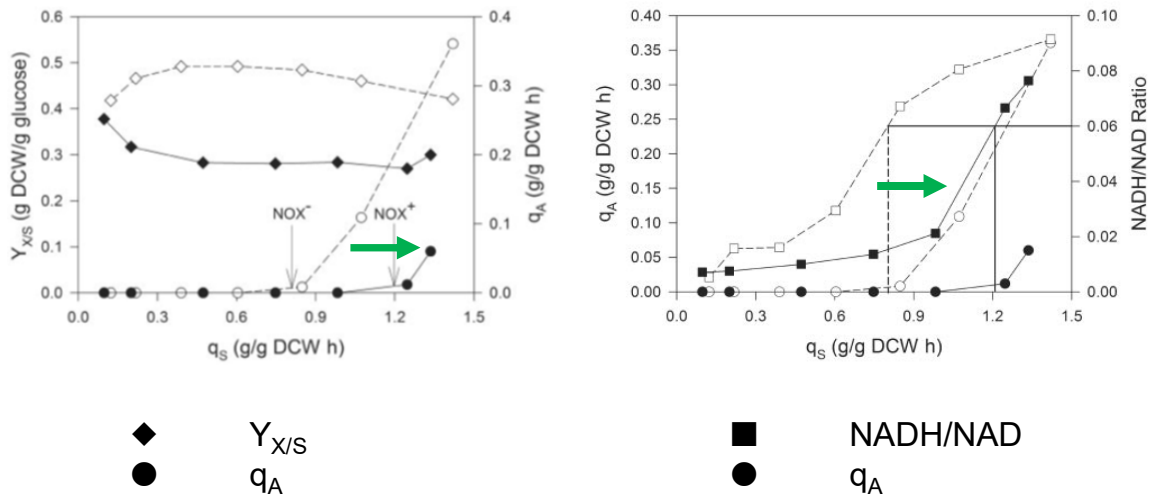

Vemuri et al., 2006

2. Respiratory capacity (in *E. coli* with *nox*)

Steady-state (chemostat)

Relieving accumulation of NADH

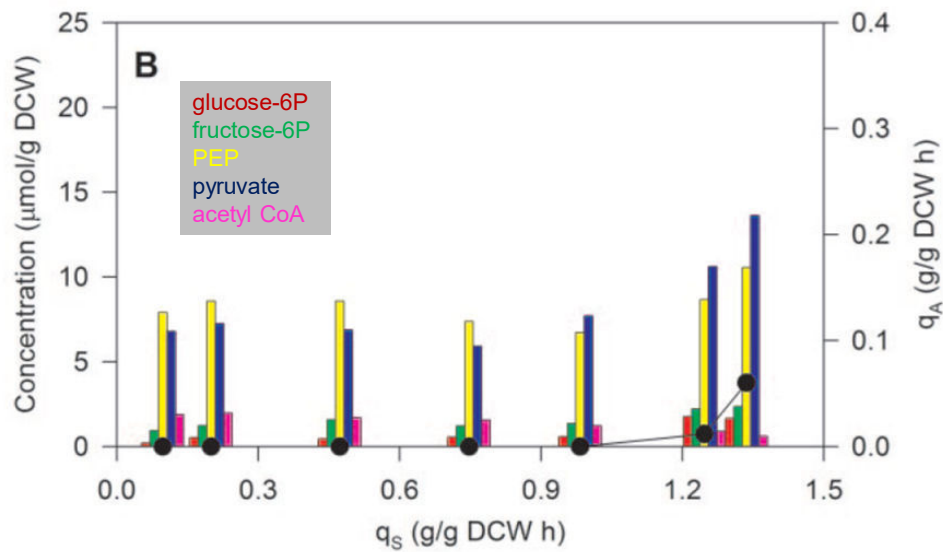

Vemuri et al., 2006

2. Respiratory capacity (in *E. coli* with *nox*)

Steady-state (chemostat)

Relieving accumulation of NADH

TCA cycle genes

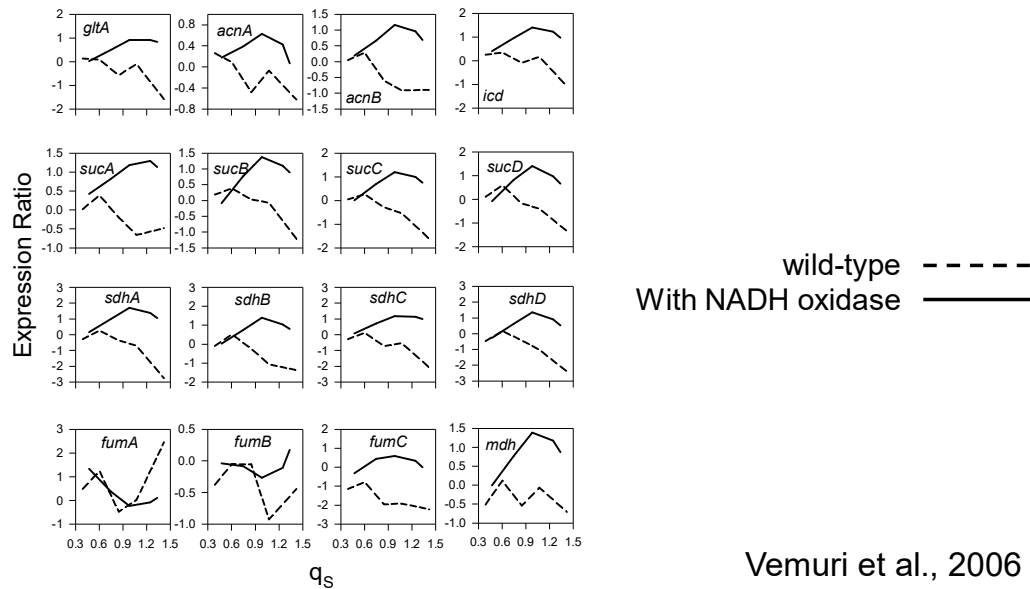

Vemuri et al., 2006

3. Nitrogen limitation

Nitrogen-limited growth in a chemostat alters metabolism compared to carbon-limited growth. The obvious difference between these two experimental conditions is that the steady-state (carbon) substrate concentration is much greater in an N-limited culture.

E. coli $D = 0.1 \text{ h}^{-1}$ Glucose_{IN} = 5 g/L (27.8 mM)

Parameter	C-limited	N-limited
Glucose Conc.	~ 0 mM	8.3 mM
q_{GLU}	1.4 mmol/gh	2.9 mmol/gh
q_{CO_2}	4.2 mmol/gh	7.2 mmol/gh
q_{ACE}	0 mol/gh	1.6 mmol/gh
% protein	70%	58%
% glycogen	1.4%	11%

Hua et al. 2003

4. Shift between N-limited and C-limited conditions

What might we **expect** as we increase inlet carbon source concentration relative to nitrogen source?

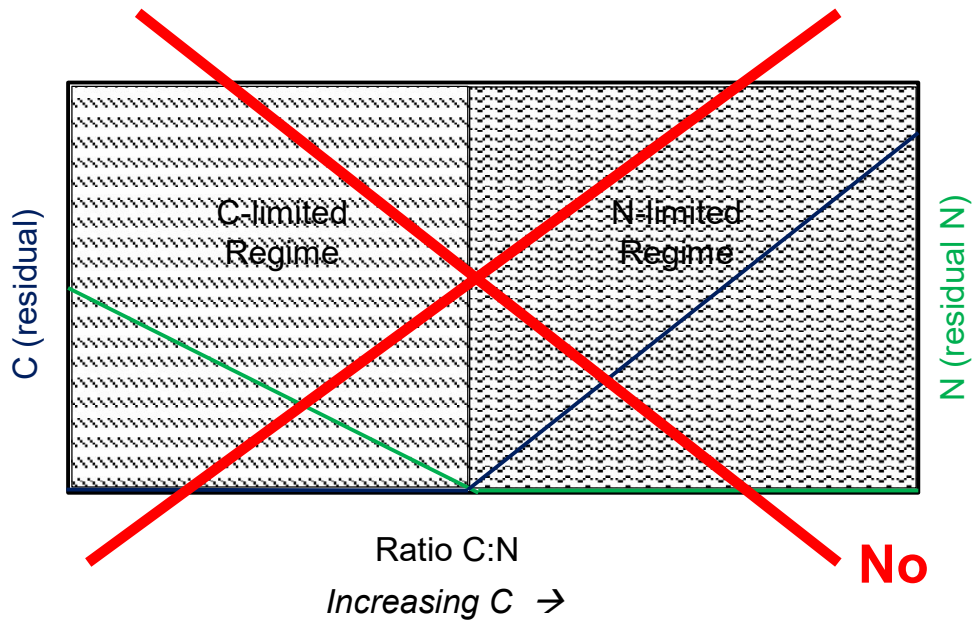

Consider the following chemostat experiment at $D = 0.054 \text{ h}^{-1}$ using *Hyphomicrobium* growing on 223 mg/L NH_4^+ with increasing concentrations of methanol (C-source):

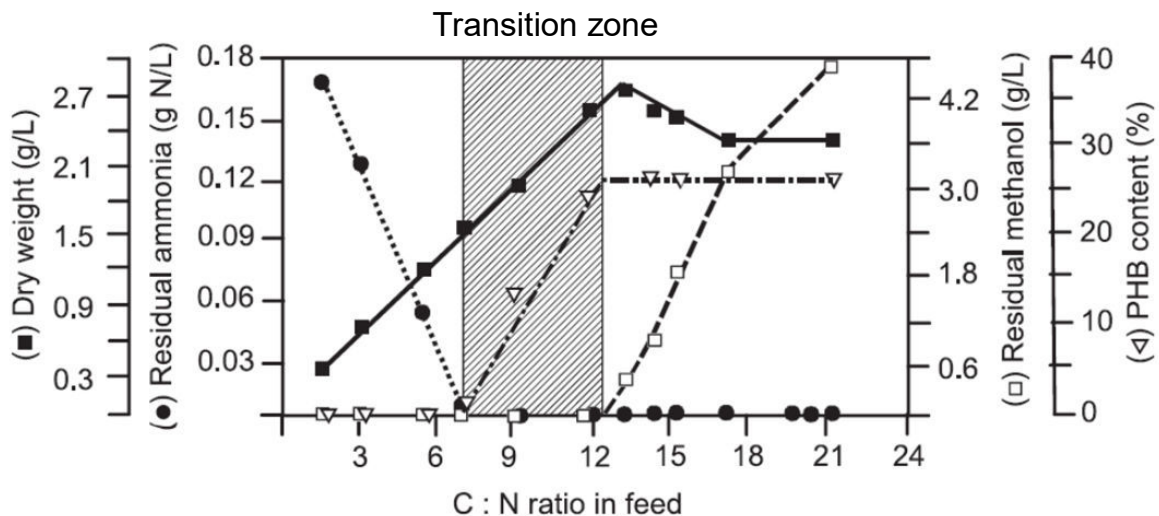

The transition zone depends on the dilution rate. For *K. pneumoniae* growing on glycerol/ NH_4^+ :

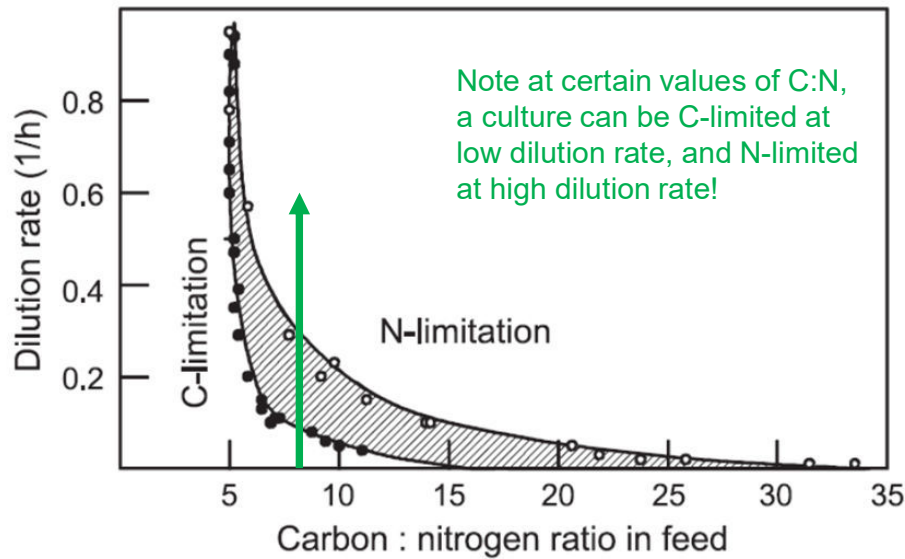

The transition zone shifts to higher C:N ratio with lower dilution rate because of higher relative maintenance (necessitating more C).

Egli and Zinn, 2003

5. Multiple carbon/energy sources

Consider the growth of *E. coli* on two sugars:

- In batch culture with glucose and lactose, *E. coli* will consume glucose immediately, and the metabolism of lactose is prevented by repression (gene) and inhibition (metabolite). When glucose is exhausted, lactose is consumed after a considerable "lag".
- In a chemostat, *E. coli* will metabolize both sugars at low dilution rates, but will metabolize only glucose at higher dilution rates. After ~50 generations, a mutant is found which grows simultaneously on both sugars in batch and in chemostat culture at any dilution rate.

Why does this occur?

cf. Harder and Dijhuizen, 1976

Consider the following study on the utilization of acetate and succinate by *Pseudomonas ovalis*. Acetate is consumed via the glyoxylate shunt (key enzyme: isocitrate lyase-ICL).

- In batch culture with succinate and acetate, *P. ovalis* will consume succinate first, then acetate.
- In batch culture with acetate, the addition of a small amount of succinate will repress ICL, preventing acetate utilization, and *P. ovalis* will switch to succinate consumption.

cf. Harder and Dijhuizen, 1976

- In chemostat culture ($D \sim 0.3 \text{ h}^{-1}$) feed about 80 mM acetate (IN):

Limiting Nutrient	succinate IN	specific activity of ICL	acetate consumption
C	0	4.5	high
C	8 mM	4.8	high
C	39 mM	2	medium
N	0	1.6	medium
N	30 mM	0.04	low

Why does this occur?

What prediction would you make at different dilution rates?

cf. Harder and Dijhuizen, 1976

6. Phosphorus limitation

- In *B. subtilis*, P-limitation increases flux through pentose phosphate pathway to >50% of glucose flux.
- In *E. coli*, the *gnd* gene encoding phosphogluconate dehydrogenase (third enzyme at entrance to pentose phosphate pathway) is upregulated 5x under P-limitation.
- Phosphatases ($R-P \rightarrow R + P_i$) are generally upregulated under P-limitation.
- Note difference in stoichiometric equations between EMP pathway and PP pathway:

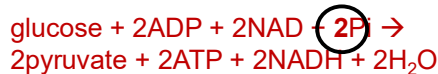

By simple mass action, P-limitation is going to favor pathway using least amount of P!

Dauner et al., 2001
VanBogelen et al., 1996

H. Exponential nutrient-limited fed-batch operation

1. Motivations

a) Oxygen Transfer

$$\text{OUR} = \text{OTR}$$

$$m_{\text{O}}X + \frac{\mu X}{Y_{X/\text{O}}} = k_L a (c_{\text{O}_2}^* - c_{\text{O}_2}^l)$$

$$0.014X + \frac{\mu X}{(1.87)} = 180(8.0 - 0.0)(0.001)$$

We examined our lab's 2.0 L fermenters, and the $k_L a$ obtained is about 180 h^{-1}

The maximum O_2 transfer occurs when the concentration of O_2 in the medium is zero.

if the culture is grown at $\mu_{\text{MAX}} = 0.80 \text{ h}^{-1}$

then $X = 3.3 \text{ g/L}$.

Which means that if we use air for O_2 transfer, the maximum cell concentration that can be reached by cells growing at μ_{MAX} is 3.3 g/L ($\text{OD} \approx 9.5$).

However, if we reduce the growth rate of cells to $\mu = 0.1 \text{ h}^{-1}$, we can reach a cell concentration of 26.1 g/L ($\text{OD} \approx 75$)

In other words, because of oxygen transfer, a culture can attain a higher ultimate cell concentration, the lower the growth rate allowed.

b) Heat Transfer

$$Q_{\text{MET}}/V = 0.12Q_{\text{O}} = 0.12 \text{ OUR} = 0.12 \left(m_{\text{O}}X + \frac{\mu X}{Y_{\text{X/O}}} \right)$$

The maximum Q_{MET}/V which can be withdrawn in a larger fermenter is about 12 kcal/Lh , meaning that the maximum OUR is about $100 \text{ mmol/Lh} = 3.2 \text{ g/Lh}$.

$$0.014X + \frac{\mu X}{(1.87)} = 3.2$$

or for a growth rate of $\mu = 0.80 \text{ h}^{-1}$...

if the culture is grown at $\mu_{\text{MAX}} = 0.80 \text{ h}^{-1}$

then $X = 7.2 \text{ g/L}$.

Which means that, based on heat transfer constraints, the maximum cell concentration that can be reached in a larger fermenter by cells growing at μ_{MAX} is 7.2 g/L ($\text{OD} \approx 20$).

However, if we reduce the growth rate of cells to $\mu = 0.1 \text{ h}^{-1}$, we can reach a cell concentration of 58 g/L .

Because of heat transfer, a culture can attain a higher ultimate cell concentration, the lower the growth rate allowed. Oxygen transfer would seem more stringent than heat transfer when air is used. When pure oxygen is used, heat transfer becomes more stringent.

c) Products

A chemostat does not allow the accumulation of a product, while a batch process does not allow a process to be run where because growth is limited, a carbon source that is in excess can be partly diverted to a desired product.

A Nutrient-Limited Fed-Batch operation allows the best of both worlds...products accumulate but cells' metabolism will often maximally generate a product.

2. Derivation

Recall the results of our material balance:

$$\frac{d(VX)}{dt} = -F_{\text{OUT}}X + \mu XV$$

$$\frac{d(VS)}{dt} = F_{\text{IN}}S_{\text{IN}} - F_{\text{OUT}}S + r_S V$$

$$\frac{d(VP)}{dt} = -F_{\text{OUT}}P + r_P V$$

$$\frac{dV}{dt} = F_{\text{IN}} - F_{\text{OUT}}$$

We will consider a process with $F_{\text{OUT}} = 0$ and $F_{\text{IN}} = F(t)$

$$\frac{d(VX)}{dt} = \mu XV$$

$$\frac{d(VS)}{dt} = F(t) S_{\text{IN}} + r_S V$$

$$\frac{d(VP)}{dt} = r_P V$$

$$\frac{dV}{dt} = F(t)$$

Obviously, volume
is not constant

How should process be operated to achieve a constant $\mu = \mu_C$?

a) Find $F(t)$

$$\frac{d(VX)}{dt} = \mu_C XV \quad \text{From cell balance}$$

$$\int_{X_0 V_0}^{XV} \frac{d(VX)}{(VX)} = \mu_C \int_0^t dt$$

$$XV = X_0 V_0 \exp(\mu_C t)$$

EQN. A

Note that $X = f_1(t)$
and $V = f_2(t)$

$$\frac{d(VS)}{dt} = F(t) S_{IN} + r_S V \quad \text{From substrate balance}$$

$$\text{or } -r_S V = F(t) S_{IN} - \cancel{\frac{VdS}{dt}} - \cancel{\frac{SdV}{dt}}$$

If S is limiting substrate, then it is fed slower than organism can consume it. Thus,

$$S \approx 0 \quad \text{and} \quad \frac{dS}{dt} \approx 0$$

$$-r_S V = F(t) S_{IN}$$

EQN. B

Recall $-r_s = m_s X + \frac{\mu X}{Y_{X/S}}$

or for $\mu = \mu_C$ $-r_s = X \left(m_s + \frac{\mu_C}{Y_{X/S}} \right)$

Inserting this equation into EQN B leads to

$$F(t) S_{IN} = XV \left(m_s + \frac{\mu_C}{Y_{X/S}} \right)$$

Inserting EQN A into this equation leads to

$$F(t) S_{IN} = X_0 V_0 \exp(\mu_C t) \left(m_s + \frac{\mu_C}{Y_{X/S}} \right)$$

$$F(t) = \frac{X_0 V_0}{S_{IN}} \left(m_s + \frac{\mu_C}{Y_{X/S}} \right) \exp(\mu_C t)$$

This equation represents the feed rate $F(t)$ needed to maintain cell growth at a constant specific growth rate of $\mu_C < \mu_{MAX}$. Note that the equation has the form:

$$F(t) = \alpha \exp(\mu_C t) \quad \text{Exponential Feed!}$$

b) Find V(t)

$$\frac{dV}{dt} = F(t) \quad \text{From 'water' balance}$$

$$\text{or} \quad \frac{dV}{dt} = \alpha \exp(\mu_C t)$$

Integrating from V_0 (at $t = t_0$) to V at t

$$V - V_0 = \frac{1}{\mu_C} [\alpha \exp(\mu_C t) - \underbrace{\alpha \exp(\mu_C t_0)}_1]$$

$$V - V_0 = \frac{\alpha}{\mu_C} [\exp(\mu_C t) - 1]$$

$$V = V_0 + \frac{\frac{X_0 V_0}{S_{IN}} \left(m_S + \frac{\mu_C}{Y_{X/S}} \right)}{\mu_C} [\exp(\mu_C t) - 1]$$

$$V(t) = V_0 (1 + \beta [\exp(\mu_C t) - 1])$$

$$\text{where } \beta = \frac{X_0}{S_{IN}} \left(\frac{m_S}{\mu_C} + \frac{1}{Y_{X/S}} \right) \quad \text{Dimensionless}$$

c) Find $X(t)$

Recall $XV = X_0V_0\exp(\mu_C t)$

$$X(t) = \frac{X_0V_0\exp(\mu_C t)}{V(t)}$$

$$X(t) = \frac{X_0\exp(\mu_C t)}{1 + \beta[\exp(\mu_C t) - 1]}$$

$$\text{where } \beta = \frac{X_0}{S_{IN}} \left(\frac{m_S}{\mu_C} + \frac{1}{Y_{X/S}} \right)$$

3. Example calculations

What feed is necessary to grow cells at $\mu_C = 0.15 \text{ h}^{-1}$?

Data:

$$V_0 = 1.5 \text{ L}$$

$$X_0 = 2.0 \text{ g/L}$$

$$S_{IN} = 500 \text{ g/L}$$

$$m_S = 0.05 \text{ g/gh}$$

$$Y_{X/S} = 0.44 \text{ g/g}$$

$$\beta = 0.0104$$

3. Example calculations (cont'd)

$$F(t) = 2.35 \exp(0.15t) \text{ [mL/h]}$$

$$V(t) = 1.4844 + 0.0156 \exp(0.15t) \text{ [L]}$$

$$X(t) = \frac{2 \exp(0.15t)}{0.9896 + 0.0104 \exp(0.15t)} \text{ [g/L]}$$

Note that cell density increases less than exponentially (because the volume is increasing and diluting the exponential growth).

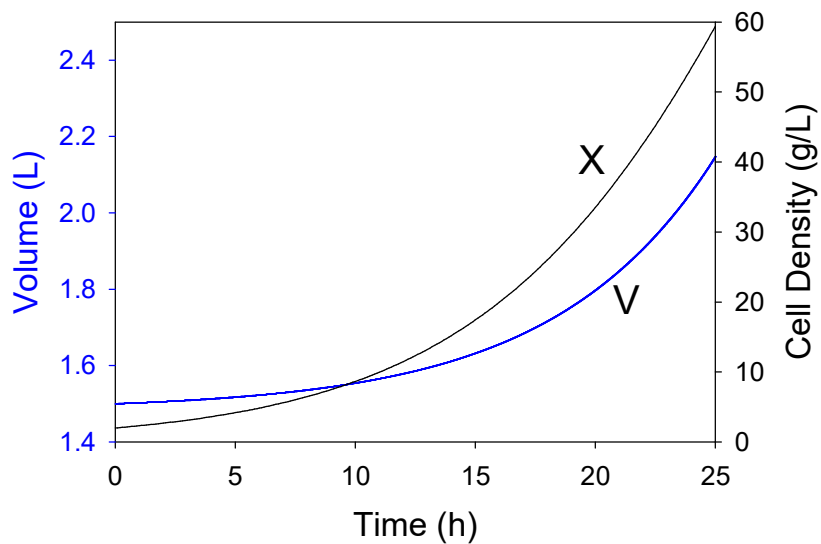

Note that these calculations presume that all other nutrients are present in excess.

I. Constant feed fed-batch operation

1. Derivation

$$F_{\text{OUT}} = 0 \text{ and } F_{\text{IN}} = F_{\text{C}} \text{ (constant)}$$

$$\frac{d(VX)}{dt} = \mu XV$$

$$\frac{d(VS)}{dt} = F_{\text{C}} S_{\text{IN}} + r_{\text{S}} V$$

$$\frac{d(VP)}{dt} = r_{\text{P}} V$$

$$\frac{dV}{dt} = F_{\text{C}}$$

2. Volume

$$V(t) = V_0 + F_{\text{C}} t$$

3. Biomass

$$\frac{d(VX)}{dt} = \mu XV$$

$$X \frac{dV}{dt} + V \frac{dX}{dt} = \mu XV$$

$$V \frac{dX}{dt} = \mu XV - X \frac{dV}{dt}$$

$$V \frac{dX}{dt} = \mu X V - X \frac{dV}{dt}$$

$$\frac{dX}{dt} = X \left(\mu - \frac{1}{V} \frac{dV}{dt} \right)$$

$$\frac{dX}{dt} = X \left(\mu - \frac{F_C}{V_0 + F_C t} \right)$$

Using Monod model to relate specific growth rate and substrate concentration:

$$\frac{dX}{dt} = X \left(\frac{\mu_{MAX} S}{K_S + S} - \frac{F_C}{V_0 + F_C t} \right)$$

Solve numerically

4. Substrate

$$\frac{d(VS)}{dt} = F_C S_{IN} + r_S V$$

$$S \frac{dV}{dt} + V \frac{dS}{dt} = F_C S_{IN} - X \left(m_S + \frac{\mu}{Y_{X/S}} \right)$$

$$\frac{dS}{dt} = \frac{1}{V} \left[F_C S_{IN} - X \left(m_S + \frac{\mu}{Y_{X/S}} \right) \right]$$

Solve numerically

Comments:

- In order to solve these three equations ($V(t)$, $X(t)$, $S(t)$), we need initial values for V , X and S .
- If the feed rate (F_C) is high enough, the value of X can decrease with time.
- If the concentration of substrate in the feed (S_{IN}) is low enough, the value of μ can decrease and the value of X can decrease with time. In this case, cells are being diluted by the incoming stream.
- The value of dS/dt is small, and the simulation equation is sensitive to variation in conditions.
- A common way to initiate a constant feed is to allow cells to grow first using an exponential feed until a desired biomass concentration is reached, and then continue (constant) feeding at 50% of that same rate.

5. Example calculations

We plan to grow cells at $\mu_C = 0.15 \text{ h}^{-1}$ (as previously shown in the exponential fed-batch culture) until $X = 20 \text{ g/L}$, then feed at 50% of that “final” feed rate. Plot the value of μ , X , and V as functions of time.

Data:

$$V_0 = 1.5 \text{ L}$$

$$X_0 = 2.0 \text{ g/L}$$

$$S_{IN} = 500 \text{ g/L}$$

$$m_S = 0.05 \text{ g/gh}$$

$$Y_{X/S} = 0.44 \text{ g/g}$$

$$\mu_C = 0.15 \text{ h}^{-1}$$

During Exponential Feed, $\beta = 0.0104$

During exponential feed:

$$F(t) = 2.35 \exp(0.15t) \text{ [mL/h]}$$

$$V(t) = 1.4844 + 0.0156 \exp(0.15t) \text{ [L]}$$

$$X(t) = \frac{2 \exp(0.15t)}{0.9896 + 0.0104 \exp(0.15t)} \text{ [g/L]}$$

We find that $X = 20 \text{ g/L}$ when $t = 16.01 \text{ h}$. At that moment, the exponential feedrate was 25.94 mL/h . So, the constant feed will start at 16.01 h at $F_C = 12.97 \text{ mL/h}$ and $V_0 = 1.657 \text{ L}$.

For constant feed, "initial" conditions are:

$$X_0 = 20 \text{ g/L}$$

$$t_0 = 16.01 \text{ h ("time = 0" for the constant phase)}$$

$$F_C = 12.97 \text{ mL/h} = 0.01297 \text{ L/h}$$

$$V_0 = 1.657 \text{ L}$$

$$S_0 = \frac{\mu_C K_S}{\mu_{MAX} - \mu_C} = \frac{(0.15 \text{ h}^{-1})(0.01 \text{ g/L})}{(0.80 \text{ h}^{-1} - 0.15 \text{ h}^{-1})} = 0.0023 \text{ g/L}$$

Coupled equations to solve numerically

$$V(t) = V_0 + F_C t$$

$$\frac{dS}{dt} = \frac{1}{V} \left[F_C (S_{IN} - S) - X \left(m_S + \frac{\mu}{Y_{X/S}} \right) \right]$$

$$\frac{dX}{dt} = X \left(\frac{\mu_{MAX} S}{K_S + S} - \frac{F_C}{V_0 + F_C t} \right)$$

$$\mu = \frac{\mu_{MAX} S}{K_S + S}$$

Exponential fed-batch followed by
Constant feed fed-batch operation

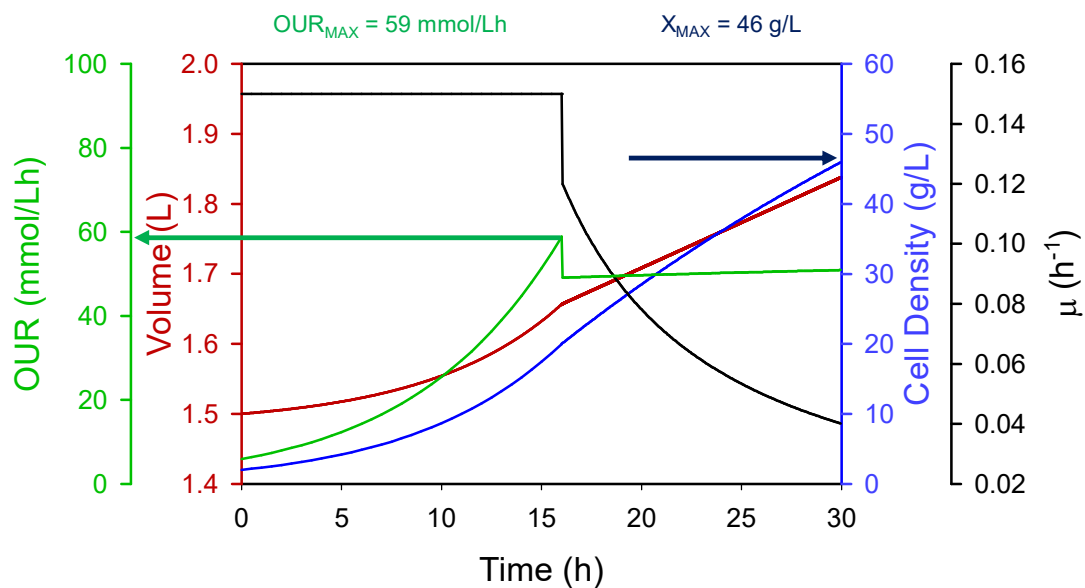

Practical Matters:

- Compare OUR_{MAX} with earlier batch processes:

Process	OUR_{MAX}	X
C-limited Batch	170 mmol/gh	12.8 g/L
N-limited Batch	91 mmol/gh	8.0 g/L
Exp/Const Fed-Batch	59 mmol/Lh	46 g/L

- A concentrated substrate feed will increase cell density quickly, and will also increase the concentration of products and inhibitors. Volume will not change much. Feed rate might be difficult to control precisely. Viscosity will be high.
- A diluted substrate feed will increase cell density slowly (or even decrease it), and will also dilute products and inhibitors. Viscosity will be lower.

Comments:

- A substrate-limited fed-batch is not the same as a fed-batch process in which the substrate concentration is controlled.

For example, if a feedback control system maintains the glucose concentration at 2.0 g/L, then the nutrient solution will indeed be fed at an exponentially increasing rate.

However, in this system the cells are determining how much nutrient is being supplied so that they can grow at their maximum rate. Thus, the cells will behave essentially like they do under nutrient-excess batch conditions.

References

- E. H. Battley (1991) Calculation of the heat of growth of *Escherichia coli* K-12 cells on succinic acid. *Biotechnol. Bioeng.* 37:334-343.
- E. H. Battley (2003) Absorbed heat and heat of formation of dried microbial biomass. *J. Therm Anal Calorim* 74:709-721.
- A. C. Cramer, S. Vlassides, D. E. Block (2002) Kinetic model for Nitrogen-limited wine fermentations. *Biotechnol. Bioeng.* 77:49-60.
- M. Dauner, T. Storni, U. Sauer (2001) *Bacillus subtilis* metabolism and energetics in carbon-limited and excess-carbon chemostat culture. *J. Bacteriol.* 183:7308-7317.
- T. Egli, M. Zinn (2003) The concept of multiple-nutrient-limited growth of microorganisms and its application in biotechnological processes. *Biotechnol. Adv.* 22:5-43.
- I. S. Farmer, C. W. Jones (1976) The energetics of *Escherichia coli* during aerobic growth in continuous culture. *Eur. J. Biochem.* 67:115-122.
- W. Harder, L. Dijkhuizen (1976) In: *Continuous Culture 6: Applications and New Fields*, A. C. R. Dean, D. C. Ellwood, C. G. T. Evans, J. Melling eds. Ellis Horwood Ltd., Chichester.

References

- A. Kayser, J. Weber, V. Hecht, U. Rinas (2005) Metabolic flux analysis of *Escherichia coli* in glucose-limited continuous culture. I. Growth-rate-dependent metabolic efficiency at steady state. *Microbiology* 151:693-706.
- J. Mandelstam, K. McQuillen. 1968. *Biochemistry of bacterial growth*. 2nd ed. Blackwell Sci. Publications Ltd. Oxford.
- A. G. Marr, E. H. Nilson, D. J. Clark (1963) The maintenance requirement of *Escherichia coli*. *Ann. NY Acad. Sci.* 102:536-548.
- A. Nanchen, A. Schicker, U. Sauer (2006) Nonlinear dependency of intracellular fluxes on growth rate in miniaturized continuous cultures of *Escherichia coli*. *Appl. Environ. Microbiol.* 72:1164-1172.
- O. M. Neijssel, M. J. Teixeira de Mattos, D. W. Tempest (1996) Growth yield and energy distribution. pp. 1683-1692. In: F. C. Neidhardt, R. Curtiss III, J. L. Ingraham, E. C. C. Lin, K. B. Low, B. Magasanik, W. S. Reznikoff, M. Riley, M. Schaechter, H. E. Umbarger (ed.), *Escherichia coli* and *Salmonella* cellular and molecular biology, 2nd. Ed. ASM Press, Washington DC.
- T. Paalme, A. Kahru, R. Elken, K. Vanatalu, R. Vilu (1995) The computer-controlled continuous culture of *Escherichia coli* with smooth change of dilution rate (A-stat). *J. Microbiol. Meth.* 24:145-153.

References

- T. Paalme, R. Elken, A. Kahru, K. Vanatalu, R. Vilu (1997) The growth rate control in *Escherichia coli* at near to maximal growth rates: the A-state approach. *Ant. van Leeuwen.* 71:217-230.
- S. J. Pirt (1965) The maintenance energy of bacteria in growing cultures. *Proc. Royal Soc. London Ser. B.* 163:224-231.
- H. E. Reiling, H. Laurila, A. Fiechter (1985) Mass culture of *Escherichia coli*: Medium development for low and high density cultivation of *Escherichia coli* B/r in minimal and complex media. *J. Biotechnol.* 2:191-206.
- H. Stouthamer, C. W. Bettenhausen. 1977. A continuous culture study of an ATPase-negative mutant of *Escherichia coli*. *Arch. Microbiol.* 113:185-189.
- P. van Hoek, J. P. Van Dijken, J. T. Pronk (1998) Effect of specific growth rate on fermentative capacity of Baker's yeast. *Appl. Environ. Microbiol.* 64:4226-4233.
- R. A. Van Bogelen, E. R. Olson, B. L. Wanner, F. C. Neidhardt (1996) Global analysis of proteins synthesized during phosphorus restriction in *Escherichia coli*. *J. Bacteriol.* 178:4344-4366.
- G. N. Vemuri, E. Altman, D. P. Sangurdekar, A. B. Khodursky, M. A. Eiteman (2006) Overflow metabolism in *Escherichia coli* during steady-state growth: transcriptional regulation and effect of the redox ratio. *Appl. Environ. Microbiol.* 72:3653-3661.